

EPOS4 Micro 24/1.5 CAN

Hardware Reference

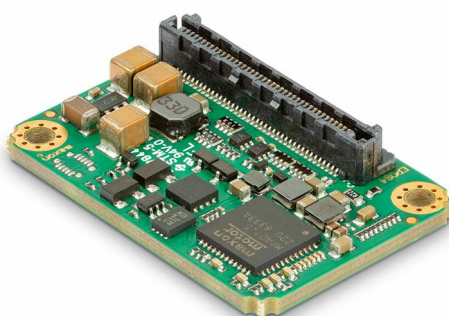

epos.maxongroup.com

TABLE OF CONTENTS

1	ABOUT	5
1.1	About this Document.	5
1.2	About the Devices.	8
1.3	About the Safety Precautions	9
2	SPECIFICATIONS	11
2.1	Technical Data	11
2.2	Thermal Data	13
2.3	Limitations.	14
2.4	Dimensional Drawings	15
2.5	Standards	16
3	SETUP	17
3.1	Generally applicable Rules	17
3.2	Pin Assignment for Micro	18
3.3	Pin Assignment for Evaluation Board	20
3.3.1	EPOS4 EB Micro (638677)	20
3.3.2	Cabling	20
3.3.3	Tools	21
3.3.4	Connections	22
3.3.4.1	Power Supply (X1)	23
3.3.4.2	Logic Supply (X2)	24
3.3.4.3	Motor (X3).	25
3.3.4.4	Hall Sensor (X4)	26
3.3.4.5	Encoder (X5)	27
3.3.4.6	Sensor (X6)	28
3.3.4.7	Digital I/O (X7)	29

READ THIS FIRST

These instructions are intended for qualified technical personnel. Prior commencing with any activities...

- you must carefully read and understand this manual and
- you must follow the instructions given therein.

The EPOS4 Micro 24/1.5 CAN positioning controller is considered as partly completed machinery according to EU Directive 2006/42/EC, Article 2, Clause (g) and is intended to be incorporated into or assembled with other machinery or other partly completed machinery or equipment.

Therefore, you must not put the device into service,...

- unless you have made completely sure that the other machinery fully complies with the EU directive's requirements!
- unless the other machinery fulfills all relevant health and safety aspects!
- unless all respective interfaces have been established and fulfill the herein stated requirements!

3.3.4.8	Analog I/O (X8)	30
3.3.4.9	RS232 (X10)	31
3.3.4.10	CAN 1 (X11) & CAN 2 (X12)	32
3.3.4.11	USB (X13)	33
3.3.5	Switch Configuration	34
3.3.5.1	DIP Switch SW1	34
3.3.5.2	Switch SW2	36
3.4	Connection Specifications	37
3.4.1	Power Supply	37
3.4.2	Logic Supply	38
3.4.3	Motor	39
3.4.4	Hall Sensor	40
3.4.5	Encoder	41
3.4.6	Sensor	44
3.4.6.1	SSI Absolute Encoder	44
3.4.6.2	High-speed Digital I/Os	46
3.4.7	Digital I/Os	49
3.4.7.1	Digital Inputs Micro	49
3.4.7.2	Digital Inputs EvaBo	50
3.4.7.3	Digital Outputs	52
3.4.8	Analog I/Os	54
3.4.9	Serial Communication Interface (SCI) / RS232	56
3.4.9.1	Micro	56
3.4.9.2	EvaBo	57
3.4.10	CAN Interface / ID Setting	58
3.4.10.1	Connection	58
3.4.10.2	Configuration	59
3.5	Status Indicators	61
4	MOTHERBOARD DESIGN GUIDE	63
4.1	Requirements for Components of Third-party Suppliers	63
4.1.1	Terminal/Socket Combo Strip	63
4.1.2	Spacers	63
4.1.3	Supply Voltage	64
4.1.4	Logic Supply Voltage	65
4.1.5	Motor Cables and Motor Chokes	66
4.1.6	RS232 Transceiver	68
4.1.7	EIA RS422 Standard for High Speed I/Os and SSI Sensor	68
4.1.8	ESD Protection	69
4.1.9	Recommended Components and Manufacturers	70
4.2	Design Guidelines	72
4.2.1	Ground	72
4.2.2	Layout	72
4.3	Terminal/Socket Placement & SMT Footprint	73

5	WIRING	75
5.1	Possible Combinations to connect a Motor.	76
5.2	Main Wiring Diagram.	78
5.3	Excerpts	79
	LIST OF FIGURES	81
	LIST OF TABLES	83
	INDEX	87

1 ABOUT

1.1 About this Document

1.1.1 Intended Purpose

Use the document to...

-stay safe,
-be fast,
-end up with set up and ready-to-go equipment.

The purpose of the present document is to familiarize you with the EPOS4 Micro 24/1.5 CAN positioning controller and its matching evaluation board. It will highlight the tasks for safe and adequate installation and/or commissioning. Follow the described instructions ...

- to avoid dangerous situations,
- to keep installation and/or commissioning time at a minimum,
- to increase reliability and service life of the described equipment.

The present document is part of a documentation set and contains performance data and specifications, information on fulfilled standards, details on connections and pin assignment, and wiring examples. The below overview shows the documentation hierarchy and the interrelationship of its individual parts:

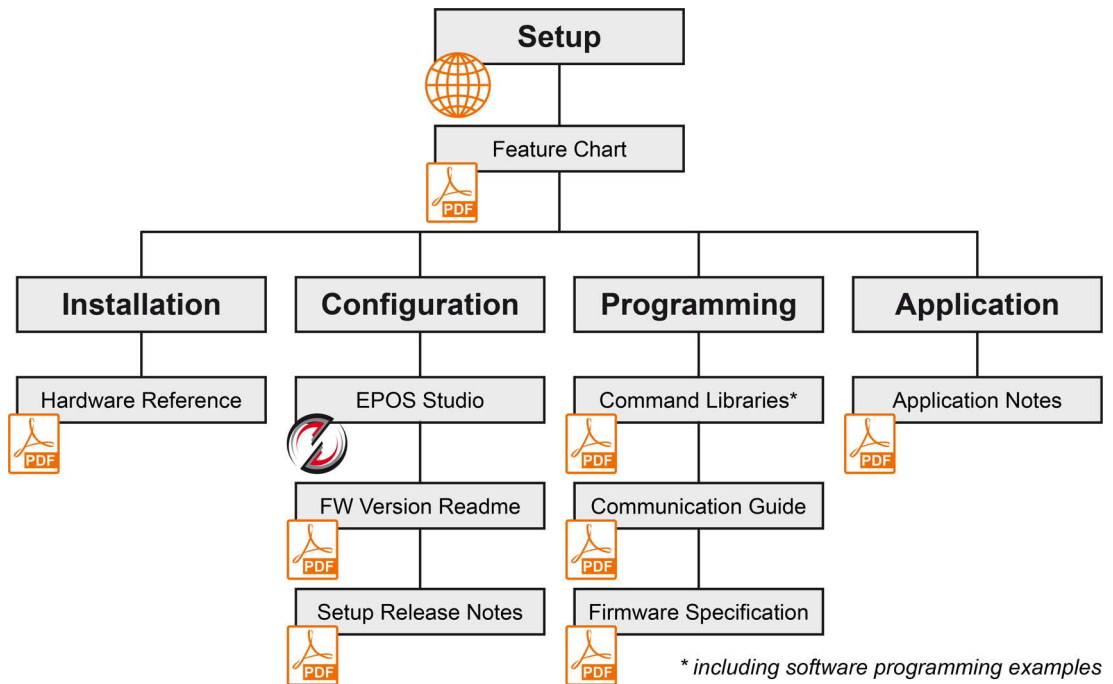

Figure 1-1 Documentation structure

1.1.2 Target Audience

The present document is intended for trained and skilled personnel. It conveys information on how to understand and fulfill the respective work and duties.

1.1.3 How to use

If not stated otherwise, the described details are valid for both the plug-in micro module and the evaluation board (→chapter “1.2 About the Devices” on page 1-8).

Throughout the document, the following notations and codes will be used.

Notation	Meaning
(n)	refers to an item (such as part numbers, list items, etc.)
→	denotes “see”, “see also”, “take note of” or “go to”

Table 1-1 Notation used

1.1.4 Symbols & Signs

In the course of the present document, the following symbols and signs will be used.







Type	Symbol	Meaning	
Safety alert	 (typical)	DANGER	Indicates an imminent hazardous situation . If not avoided, it will result in death or serious injury .
		WARNING	Indicates a potential hazardous situation . If not avoided, it can result in death or serious injury .
		CAUTION	Indicates a probable hazardous situation or calls the attention to unsafe practices. If not avoided, it may result in injury .
Prohibited action	 (typical)	Indicates a dangerous action. Hence, you must not!	
Mandatory action	 (typical)	Indicates a mandatory action. Hence, you must!	
Information		Requirement / Note / Remark	Indicates an activity you must perform prior continuing, or gives information on a particular item you need to observe.
		Best practice	Indicates an advice or recommendation on the easiest and best way to further proceed.
		Material Damage	Indicates information particular to possible damage of the equipment.

Table 1-2 Symbols and signs

1.1.5 Trademarks and Brand Names

For easier legibility, registered brand names are listed below and will not be further tagged with their respective trademark. It must be understood that the brands (the list below is not necessarily concluding) are protected by copyright and/or other intellectual property rights even if their legal trademarks are omitted in the later course of this document.

Brand name	Trademark owner
Adobe® Reader®	© Adobe Systems Incorporated, USA-San Jose, CA
CANopen® CiA®	© CiA CAN in Automation e.V, DE-Nuremberg
CLIK-Mate™ Micro-Fit™ Mini-Fit Jr.™ Mini-Fit Plus™ Mega-Fit®	© Molex, USA-Lisle, IL
EtherCAT®	© EtherCAT Technology Group, DE-Nuremberg, licensed by Beckhoff Automation GmbH, DE-Verl
Linux®	© Linus Torvalds (The Linux Foundation, USA-San Francisco CA)
Littelfuse®	© Littelfuse Inc., USA-Chicago, IL
Windows®	© Microsoft Corporation, USA-Redmond, WA

Table 1-3 Brand names and trademark owners

1.1.6 Copyright

© 2026 maxon. All rights reserved. Any use, in particular reproduction, editing, translation, and copying, without prior written approval is not permitted (contact: maxon international ltd., Brünigstrasse 220, CH-6072 Sachseln, +41 41 666 15 00, www.maxongroup.com). Infringements will be prosecuted under civil and criminal law. The mentioned trademarks belong to their respective owners and are protected under trademark laws. Subject to change without prior notice.

CCMC | EPOS4 Micro 24/1.5 CAN Hardware Reference | Edition 2026-05 | DocID rel13570

1.2 About the Devices

Capabilities of the device, included features, and supported motors.

The EPOS4 Micro 24/1.5 CAN is a miniaturized, full digital, smart positioning control unit. Its high power density allows flexible use for brushed DC and brushless EC (BLDC) motors up to approximately 36 Watts with various feedback options, such as Hall sensors, incremental encoders as well as absolute sensors in a multitude of drive applications.

The device is specially designed to be commanded and controlled as a slave node in a CANopen network. In addition, the unit can be operated via any USB or RS232 communication port of a Windows or Linux workstation (RS232 communication requires an external transceiver).

Latest technology, such as field-oriented control (FOC), acceleration/velocity feed forward, or dual loop, in combination with highest control cycle rates allow sophisticated, ease-of-use motion control.

The EPOS4 Micro 24/1.5 CAN can be incorporated into customer-specific motherboards for single axis or multi axes motion control systems. For initial commissioning, the EPOS4 Micro 24/1.5 CAN can be operated with the optionally available «EPOS4 EB Micro» evaluation board. The controller is available in the following configurations:

- **EPOS4 Micro 24/1.5 CAN (951711)**
Plug-in micro module for use with customer-specific motherboards
- **EPOS4 EB Micro (638677)**
Evaluation board for initial commissioning providing all connectors, including communication interfaces

For easier legibility, in the later course of this document naming of components will be as follows:



Note

The evaluation board is also applicable to the EPOS4 Micro 24/1.5. This applies even if the labeling on the evaluation board only shows "EPOS4 Micro 24/5".

Short form	Meaning
EPOS4	all controller versions as well as other EPOS4 positioning controllers as a whole
EvaBo	evaluation board EPOS4 EB Micro
Micro	EPOS4 Micro 24/1.5 CAN

Table 1-4 Abbreviations



Find the latest edition of the present document as well as additional documentation and software for EPOS4 positioning controllers also on the Internet: →<http://epos.maxongroup.com>.

In addition, you may wish to browse the EPOS video library. It features video tutorials that provide easy to follow instructions on how to get started with «EPOS Studio» and shows you tips and tricks on how to setup communication interfaces, and so on. Explore on Vimeo: →<https://vimeo.com/album/4646388>

1.3 About the Safety Precautions

Keep in mind:
Safety first!
Always!

- Make sure that you have read and understood the note “READ THIS FIRST” on page A-2!
- Do not engage with any work unless you possess the stated skills (→chapter “1.1.2 Target Audience” on page 1-5)!
- Refer to →chapter “1.1.4 Symbols & Signs” on page 1-6 to understand the subsequently used indicators!
- You must observe any regulation applicable in the country and/or at the site of implementation with regard to health and safety/accident prevention and/or environmental protection!



DANGER

High voltage and/or electrical shock

Touching live wires causes death or serious injuries!

- Consider any power cable as connected to live power, unless having proven the opposite!
- Make sure that neither end of cable is connected to live power!
- Make sure that power source cannot be engaged while work is in process!
- Obey lock-out/tag-out procedures!
- Make sure to securely lock any power engaging equipment against unintentional engagement and tag it with your name!



Requirements

- Make sure that all associated devices and components are installed according to local regulations.
- Be aware that, by principle, an electronic apparatus can not be considered fail-safe. Therefore, you must make sure that any machine/apparatus has been fitted with independent monitoring and safety equipment. If the machine/apparatus should break down, if it is operated incorrectly, if the control unit breaks down or if the cables break or get disconnected, etc., the complete drive system must return – and be kept – in a safe operating mode.
- Be aware that you are not entitled to perform any repair on components supplied by maxon.



Electrostatic sensitive device (ESD)

- Wear working cloth and use equipment in compliance with ESD protective measures.
- Handle device with extra care.

••page intentionally left blank••

2 SPECIFICATIONS

2.1 Technical Data

EPOS4 Micro 24/1.5 CAN (951711)			
Electrical Rating	Nominal power supply voltage $+V_{CC}$	10...24 VDC	
	Nominal logic supply voltage $+V_C$	10...24 VDC	
	Absolute supply voltage $+V_{min} / +V_{max}$	8 VDC / 28 VDC	
	Output voltage (max.)	$0.9 \times +V_{CC}$	
	Output current $I_{cont} / I_{max} (<10 \text{ s})$	1.5 A / 4.5 A	
	Pulse Width Modulation frequency	50 kHz	
	Sampling rate PI current controller	25 kHz (40 μ s)	
	Sampling rate PI speed controller	2.5 kHz (400 μ s)	
	Sampling rate PID positioning controller	2.5 kHz (400 μ s)	
	Sampling rate analog input	2.5 kHz (400 μ s)	
	Max. efficiency	95.8% (→Figure 2-3)	
	Max. speed DC motor	limited by max. permissible speed (motor) and max. output voltage (controller)	
	Max. speed EC motor (block)	100'000 rpm (1 pole pair)	
	Max. speed EC motor (sinusoidal)	50'000 rpm (1 pole pair)	
	Built-in motor choke	Micro	—
EvaBo		3 x 15 μ H; 5 A	
Inputs & Outputs	Digital Input 1 (general purpose) Digital Input 2 (general purpose) Digital Input 3 (general purpose) Digital Input 4 (general purpose)	Micro EvaBo	+2.1...+36 VDC DIP switch-selectable levels: • Logic: +2.0...+30 VDC • PLC: +9.0...+30 VDC
	Digital Output 1 (general purpose) Digital Output 2 (general purpose)		max. 36 VDC / $I_L \leq 500 \text{ mA}$ (open collector with internal pull-up)
	Analog Input 1 Analog Input 2		Resolution 12-bit, -10...+10 V, 10 kHz, differential
	Analog Output 1		Resolution 12-bit, -4...+4 V, 25 kHz, referenced to GND
	Digital Hall sensor signals H1, H2, H3		+2.0...+24 VDC (internal pull-up)
	Digital incremental encoder signals A, A\, B, B\, I, I\		EIA RS422, max. 6.25 MHz

Continued on next page.

EPOS4 Micro 24/1.5 CAN (951711)			
Inputs & Outputs (Continued)	Sensor signals (choice between multiple functions)	Micro	single-ended
	<ul style="list-style-type: none"> SSI absolute encoder (configurable, 0.4...2 MHz) High-speed digital input 4 and High-speed digital output 1 (max. 6.25 MHz) 	EvaBo	EIA RS422
Voltage Outputs	Sensor supply voltage V_{Sensor}	Micro	+5 VDC / $I_L \leq 145$ mA
	Auxiliary output voltage V_{DD}	EvaBo	+5 VDC / $I_L \leq 300$ mA
Motor Connections	DC motor	+ Motor, - Motor	
	EC motor	Motor winding 1, Motor winding 2, Motor winding 3	
Interfaces		Micro	EvaBo
	USB 2.0 / USB 3.0	Full Speed	Full Speed
	RS232	max. 115'200 bit/s; external transceiver necessary	max. 115'200 bit/s
	CAN	max. 1 Mbit/s	max. 1 Mbit/s
Status Indicators		Micro	EvaBo
	Device status	Operation (green) Error (red)	—
Physical		Micro	EvaBo
	Weight	approx. 6 g	approx. 80 g
	Dimensions (L x W x H)	32.0 x 22.0 x 7.0 mm	100.0 x 90.0 x 22.5 mm
	Mounting	mounting holes for M2 screws	mounting holes $\varnothing 4$ mm with mounted spacers
Environment	Temperature	Operation	-30...+62 °C
		Extended range [a]	+62...+68.8 °C Derating -0.210 A/°C (→Figure 2-2)
		Storage	-40...+85 °C
	Altitude [b]	Operation	0...6'000 m MSL
		Extended range [a]	6'000...10'000 m MSL Derating →Figure 2-2
		Humidity	5...90% (condensation not permitted)

[a] Operation within the extended range (temperature and altitude) is permitted. However, a respective derating (declination of output current I_{cont}) as to the stated values will apply.

[b] Operating altitude in meters above Mean Sea Level, MSL.

Table 2-5 Technical data

2.2 Thermal Data



Thermal interconnection of the devices

The stated thermal data are only valid with the «EPOS4 Micro 24/1.5 CAN» mounted onto the evaluation board and attached with the respective screws. Thereby, the screws establish a thermal interconnection of the two devices.

2.2.1 Derating of Output Current

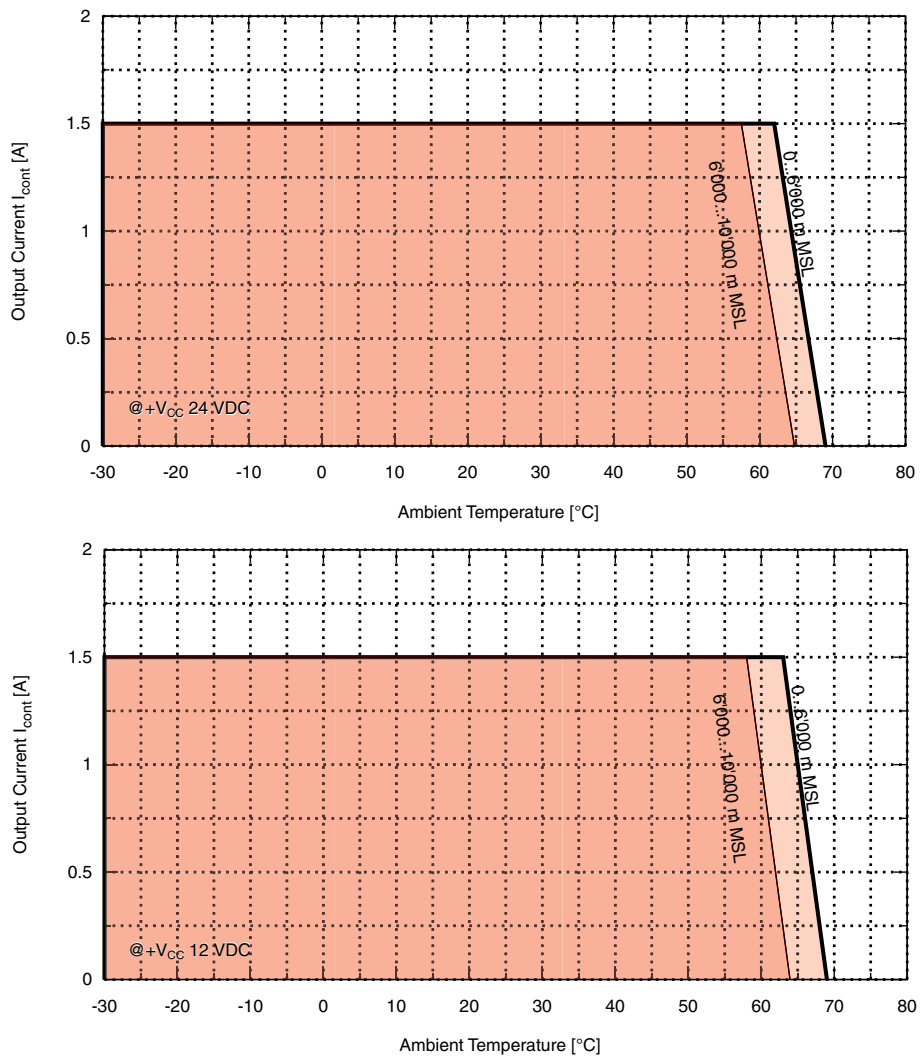

Figure 2-2 Derating of output current

2.2.2 Power Dissipation and Efficiency

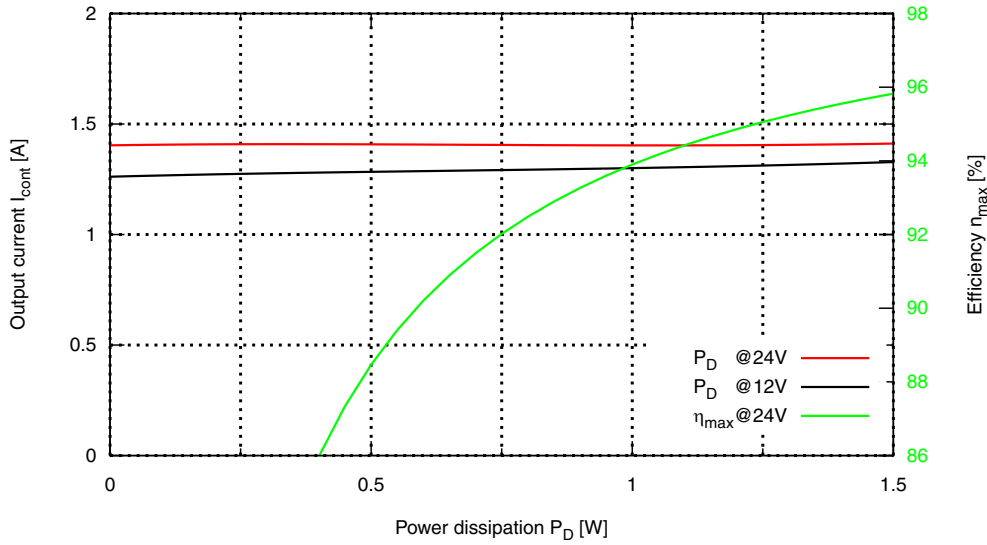

Figure 2-3 Power dissipation and efficiency – EPOS4 Micro 24/1.5 CAN

2.3 Limitations

Protection functionality	Switch-off threshold	Recovery threshold
Undervoltage	7.0 V	7.5 V
Overvoltage	32 V	29 V
Overcurrent	6 A	—
Thermal overload	90 °C	85 °C

Table 2-6 Limitations

2.4 Dimensional Drawings

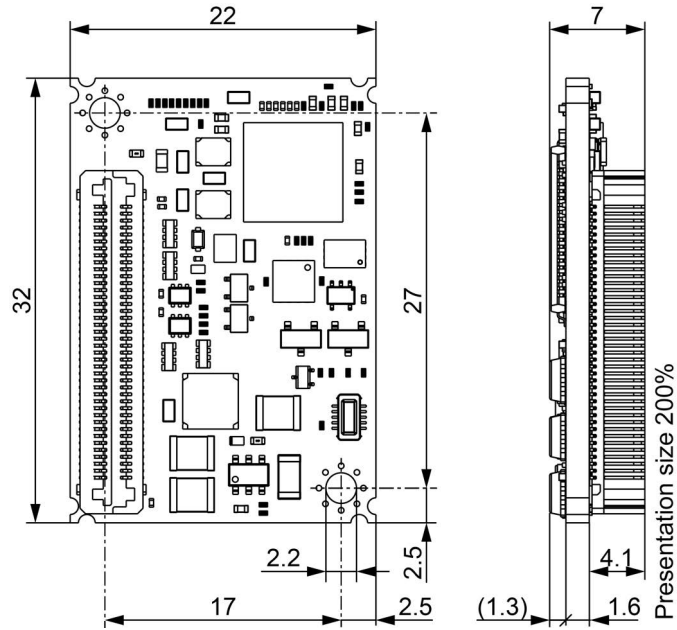

Figure 2-4 EPOS4 Micro 24/1.5 CAN – Dimensional drawing [mm]

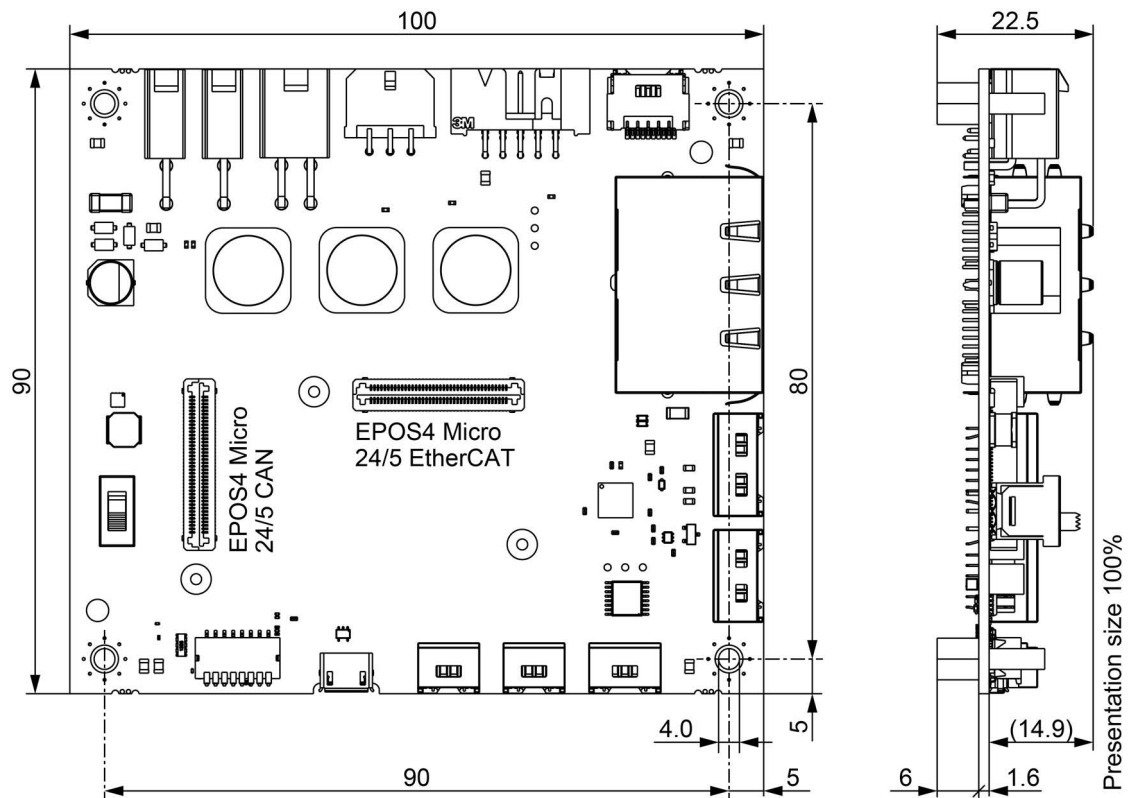

Figure 2-5 EPOS4 EB Micro – Dimensional drawing [mm]

2.5 Standards

The described device has been successfully tested for compliance with the below listed standards. In practical terms, only the complete system (the fully operational equipment comprising all individual components, such as motor, servo controller, power supply unit, EMC filter, cabling etc.) can undergo an EMC test to ensure interference-free operation.



Important Notice

The device's compliance with the mentioned standards does not imply its compliance within the final, ready to operate setup. In order to achieve compliance of your operational system, you must perform EMC testing of the involved equipment as a whole.

Electromagnetic compatibility		
Generic	IEC/EN 61000-6-2	Immunity for industrial environments
	IEC/EN 61000-6-3	Emission standard for residential, commercial and light-industrial environments
Applied	IEC/EN 55032 (CISPR32)	Radio disturbance characteristics / radio interference
	IEC/EN 61000-4-3	Radiated, radio-frequency, electromagnetic field immunity test >10 V/m
	IEC/EN 61000-4-4	Electrical fast transient/burst immunity test ± 2 kV
	IEC/EN 61000-4-6	Immunity to conducted disturbances, induced by radio-frequency fields 10 Vrms
Others		
Environment	IEC/EN 60068-2-6	Environmental testing – Test Fc: Vibration (sinusoidal, 10...500 Hz, 20 m/s ²)
	MIL-STD-810F	Random transport (10...500 Hz up to 2.53 g _{rms})
Safety	UL File Number	Unassembled printed circuit board <ul style="list-style-type: none"> • Micro: E207844 • EvaBo: E305654
Reliability	MIL-HDBK-217F	Reliability prediction of electronic equipment Environment: Ground, benign (GB) Ambient temperature: 298 K (25 °C) Component stress: In accordance with circuit diagram and nominal power Mean Time Between Failures (MTBF) <ul style="list-style-type: none"> • Micro: 945'031 hours

Table 2-7 Standards

3 SETUP

IMPORTANT NOTICE: PREREQUISITES FOR PERMISSION TO COMMENCE INSTALLATION

The EPOS4 Micro 24/1.5 CAN positioning controller is considered as partly completed machinery according to EU Directive 2006/42/EC, Article 2, Clause (g) and **is intended to be incorporated into or assembled with other machinery or other partly completed machinery or equipment.**



WARNING

Risk of injury

Operating the device without the full compliance of the surrounding system with the EU Directive 2006/42/EC may cause serious injuries!

- Do not operate the device, unless you have made completely sure that the other machinery fully complies with the EU directive's requirements!
- Do not operate the device, unless the other machinery fulfills all relevant health and safety aspects!
- Do not operate the device, unless all respective interfaces have been established and fulfill the requirements stated in this document!

3.1 Generally applicable Rules



Maximal permitted supply voltage

- Make sure that supply power is between 10...24 VDC.
- Supply voltages above 32 VDC, or wrong polarity will destroy the unit.
- Note that the necessary output current is depending on the load torque. Yet, the output current limits are as follows:
 - continuous max. 1.5 A
 - short-time (acceleration) max. 4.5 A



Hot plugging the USB interface may cause hardware damage

If the USB interface is being hot-plugged (connecting while the power supply is on), the possibly high potential differences of the two power supplies of controller and PC/Notebook can lead to damaged hardware.

- Avoid potential differences between the power supply of controller and PC/Notebook or, if possible, balance them.
- Insert the USB connector first, then switch on the power supply of the controller.

3.2 Pin Assignment for Micro

For in-depth details on connections → chapter “3.4 Connection Specifications” on page 3-37.

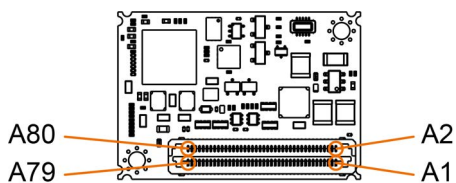

Figure 3-6 Pin assignment

Pin	Signal	Description
A1...A6**	Motor (+M)	DC motor: Motor +
	Motor winding 1	EC motor: Winding 1
A7...A12**	Motor (-M)	DC motor: Motor -
	Motor winding 2	EC motor: Winding 2
A13...A18**	Motor winding 3	EC motor: Winding 3
A19...A24**	+V _{CC}	Power supply voltage (+10...+24 VDC)
A25	GND	Ground
A26	+V _C	Logic supply voltage (+10...+24 VDC)
A27...A32**	GND	Ground
A33	Hall sensor 1	Hall sensor 1 input
A34	Channel A	Digital incremental encoder channel A
A35	Hall sensor 2	Hall sensor 2 input
A36	Channel A\	Digital incremental encoder channel A complement
A37	Hall sensor 3	Hall sensor 3 input
A38	Channel B	Digital incremental encoder channel B
A39	V _{Sensor}	Sensor supply voltage (+5 VDC; I _L ≤145 mA)
A40	Channel B\	Digital incremental encoder channel B complement
A41	DigIN1	Digital input 1
A42	Channel I	Digital incremental encoder channel I
A43	DigIN2	Digital input 2
A44	Channel I\	Digital incremental encoder channel I complement
A45	DigIN3	Digital input 3
A46	AnIN1+	Analog input 1, positive signal
A47	DigIN4	Digital input 4
A48	AnIN1-	Analog input 1, negative signal
A49	DigOUT1	Digital output 1
A50	AnIN2+	Analog input 2, positive signal
A51	DigOUT2	Digital output 2
A52	AnIN2-	Analog input 2, negative signal
A53	Data	Data (SSI)
	HsDigIN4	High-speed digital input 4
A54	AnOUT1	Analog output 1

Continued on next page.

Pin	Signal	Description
A55	Clock	Clock (SSI)
	HsDigOUT1	High-speed digital output 1
A56	—	not connected
A57...A58	GND	Ground
A59	USB_D-	USB Data-
A60	V _{Bus}	USB bus supply voltage input +5 VDC
A61	USB_D+	USB Data+
A62	—	not connected
A63...A64	GND	Ground
A65	ID 1	CAN ID 1 (valence = 1)
A66	ID 5	CAN ID 5 (valence = 16)
A67	ID 2	CAN ID 2 (valence = 2)
A68	ID 6	CAN ID 6 (valence = 32)
A69	—	not connected
A70	—	not connected
A71	ID 3	CAN ID 3 (valence = 4)
A72	Auto bit rate	Automatic bit rate detection of CAN bus
A73	ID 4	CAN ID 4 (valence = 8)
A74	—	not connected
A75...A76	GND	Ground
A77	DSP_RxD	Serial communication interface receive (UART)
A78	DSP_TxD	Serial communication interface transmit (UART)
A79	CAN high	CAN high bus line
A80	CAN low	CAN low bus line

** Connect all pins in respect to the individual pin current rating.

Table 3-8 Pin assignment A1...A80

3.3 Pin Assignment for Evaluation Board

For easy initial commissioning, a ready-made evaluation board is available to connect with the Micro. It comprises all required connections.

For in-depth details on connections → chapter “3.4 Connection Specifications” on page 3-37.

3.3.1 EPOS4 EB Micro (638677)

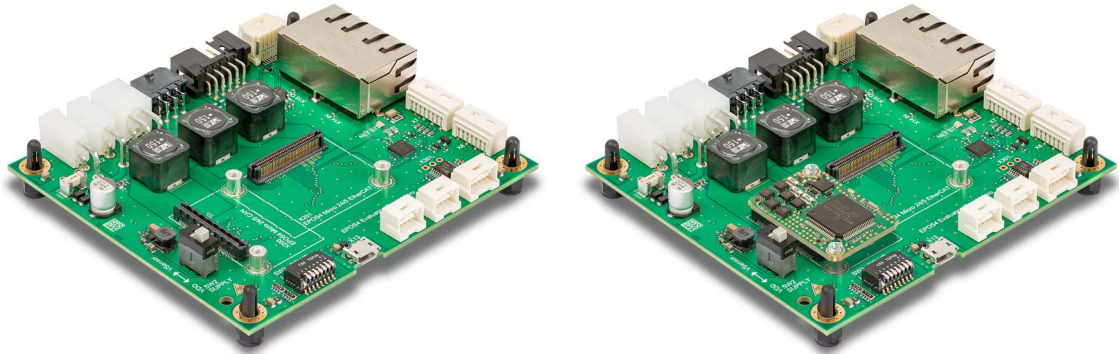

Figure 3-7 EPOS4 EB Micro (without/with EPOS4 Micro 24/1.5 CAN)

3.3.2 Cabling

PLUG&PLAY

Take advantage of maxon’s prefab cable assemblies. They come as ready-to-use parts and will help to reduce commissioning time to a minimum.

- a) Check the following table and find the part number of the cable assembly that matches the setup you will be using.
- b) Follow the cross-reference to get the cable’s pin assignment.

Connector	Prefab Cable Assembly			
	EvaBo	Designation	Part Number	→Page
X1		Power Cable	275829	3-23
X2		Power Cable	275829	3-23
X3		Motor Cable	275851	3-25
X4		Hall Sensor Cable	275878	3-26
X5		Encoder Cable	275934	3-27
X6		Sensor Cable 5x2core	520852	3-28
X7		Signal Cable 8core	520853	3-29
X8		Signal Cable 7core	520854	3-30
X10		RS232-COM Cable	520856	3-31
X11		CAN-COM Cable	520857	3-32
		CAN-CAN Cable	520858	3-32
X12		CAN-COM Cable	520857	3-32
		CAN-CAN Cable	520858	3-32
X13		USB Type A - micro B Cable	403968	3-33

Table 3-9 Prefab maxon cables

MAKE&BAKE YOUR OWN

If you decide not to employ maxon’s prefab cable assemblies, you might wish to use the prepackaged kit that contains all connectors required to make up your own cabling.

EPOS4 Connector Set (520859)		
Connector	Specification	Quantity
Connectors		
—	Molex Mega-Fit, 2 poles (171692-0102)	1
X1 / X2	Molex Mini-Fit Jr., 2 poles (39-01-2020)	2
X3	Molex Mini-Fit Jr., 4 poles (39-01-2040)	1
—	Molex Mega-Fit, 4 poles (171692-0104)	1
X4	Molex Micro-Fit 3.0, 6 poles (430-25-0600)	1
X6	Molex CLIK-Mate, dual row, 10 poles (503149-1000)	1
X7	Molex CLIK-Mate, single row, 8 poles (502578-0800)	2
X8	Molex CLIK-Mate, single row, 7 poles (502578-0700)	1
X10	Molex CLIK-Mate, single row, 5 poles (502578-0500)	1
X11 / X12	Molex CLIK-Mate, single row, 4 poles (502578-0400)	2
Crimp Terminals		
—	Molex Mega-Fit, female crimp terminal (172063-0311)	7
X1 / X2 / X3	Molex Mini-Fit Plus crimp terminal (45750-1111)	9
X4	Molex Micro-Fit 3.0 female crimp terminal (43030-0010)	7
X6...X12	Molex CLIK-Mate crimp terminal (502579-0100)	45
Accessories		
X5	3M Retainer Clip with strain relief, height 13.5 mm (3505-8110)	1

Table 3-10 EPOS4 Connector Set – Content

3.3.3 Tools

Tool	Manufacturer	Part Number
Hand crimper for CLIK-Mate crimp terminals	Molex	63819-4600
Hand crimper for Micro-Fit 3.0 crimp terminals	Molex	63819-0000
Hand crimper for Mini-Fit crimp terminals	Molex	63819-0900

Table 3-11 Recommended tools

3.3.4 Connections

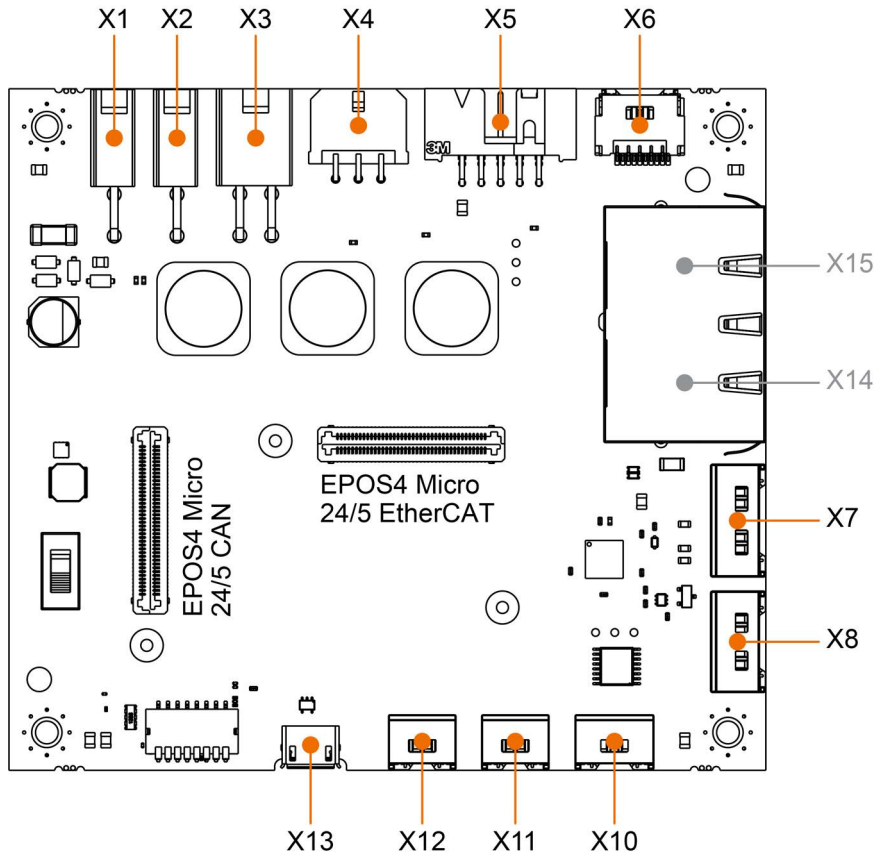

X1	Power Supply →page 3-23	X8	Analog I/O →page 3-30
X2	Logic Supply →page 3-24	X10	RS232 →page 3-31
X3	Motor →page 3-25	X11	CAN 1 →page 3-32
X4	Hall Sensor →page 3-26	X12	CAN 2 →page 3-32
X5	Encoder →page 3-27	X13	USB →page 3-33
X6	Sensor →page 3-28	X14	EtherCAT IN [c]
X7	Digital I/O →page 3-29	X15	EtherCAT OUT [c]

[c] Only available with EPOS4 Micro 24/1.5 EtherCAT

Figure 3-8 Connector Boards – Connectors



How to read pin assignment tables

- The first column describes both the pin number of the connector and of the matching prefab maxon cable's Head A.
- The second column describes the cable core color of the prefab maxon cable.
- The third column describes the pin number of the prefab maxon cable's Head B.

3.3.4.1 Power Supply (X1)



Best practice

Keep the motor mechanically disconnected during the setup and adjustment phase.

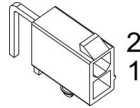

Figure 3-9 Power supply connector X1

X1 Head A Pin	Prefab Cable Color	Head B Pin	Signal	Description
1	black	-	GND	Ground
2	black	+	+V _{CC}	Power supply voltage (+10...+24 VDC)

Table 3-12 Power supply connector X1 – Pin assignment

Power Cable (275829)		
A		B
Cross-section	2 x 0.75 mm ² , grey	
Length	3 m	
Head A	Plug	Molex Mini-Fit Jr., 2 poles (39-01-2020)
	Contacts	Molex Mini-Fit Plus crimp terminals (45750)
Head B	Wire end sleeves 0.75 mm ²	

Table 3-13 Power Cable

3.3.4.2 Logic Supply (X2)

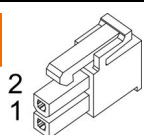

Separate power supply

The logic part of the controller may be supplied by separate supply voltage

- *Micro: The logic supply must be connected separately.*
- *EvaBo: If not supplied separately, the logic supply is internally connected to the power supply.*

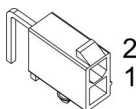

Figure 3-10 Logic supply connector X2

X2 Head A Pin	Prefab Cable Color	Head B Pin	Signal	Description
1	black	-	GND	Ground
2	black	+	+V _C	Logic supply voltage (+10...+24 VDC)

Table 3-14 Logic supply connector X2 – Pin assignment

For the matching prefab cable assembly → Table 3-13.

3.3.4.3 Motor (X3)

The controller is set to drive either maxon EC motor (BLDC, brushless DC motor) or maxon DC motor (brushed DC motor) with separated motor/encoder cable.

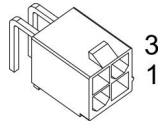

Figure 3-11 Motor connectors X3

X3 Head A Pin	Prefab Cable Color	Head B Pin	Signal	Description
1	white		Motor (+M)	DC motor: Motor +
2	brown		Motor (-M)	DC motor: Motor -
3	green		—	not connected
4	black		Motor shield	Cable shield

Table 3-15 Motor connector X3 – Pin assignment for maxon DC motor

X3 Head A Pin	Prefab Cable Color	Head B Pin	Signal	Description
1	white		Motor winding 1	EC motor: Winding 1
2	brown		Motor winding 2	EC motor: Winding 2
3	green		Motor winding 3	EC motor: Winding 3
4	black		Motor shield	Cable shield

Table 3-16 Motor connector X3– Pin assignment for maxon EC motor

Motor Cable for X3 (275851)		
A		B
Cross-section	3 x 0.75 mm ² , shielded, grey	
Length	3 m	
Head A	Plug	Molex Mini-Fit Jr., 4 poles (39-01-2040)
	Contacts	Molex Mini-Fit Plus crimp terminals (45750)
Head B	Wire end sleeves 0.75 mm ²	

Table 3-17 Motor Cable

3.3.4.4 Hall Sensor (X4)

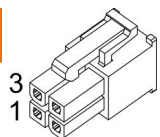
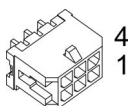

Figure 3-12 Hall sensor connector X4

X4 Head A Pin	Prefab Cable Color	Head B Pin	Signal	Description
1	green		Hall sensor 1	Hall sensor 1 input
2	brown		Hall sensor 2	Hall sensor 2 input
3	white		Hall sensor 3	Hall sensor 3 input
4	yellow		GND	Ground
5	grey		V _{Sensor}	Sensor supply voltage (+5 VDC; I _L ≤ 145 mA)
6	black		Hall shield	Cable shield

Table 3-18 Hall sensor connector X4 – Pin assignment

Hall Sensor Cable (275878)		
Cross-section	5 x 0.14 mm ² , shielded, grey	
Length	3 m	
Head A	Plug	Molex Micro-Fit 3.0, 6 poles (430-25-0600)
	Contacts	Molex Micro-Fit 3.0 female crimp terminals (430-30-xxxx)
Head B	Wire end sleeves 0.14 mm ²	

Table 3-19 Hall Sensor Cable

3.3.4.5 Encoder (X5)

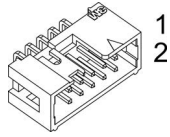

Figure 3-13 Encoder connector X5

X5 Head A Pin	Prefab Cable Color	Head B Pin	Signal	Description
1	brown	1	—	not connected
2	white	2	V_{Sensor}	Sensor supply voltage (+5 VDC; $I_L \leq 145 \text{ mA}$)
3	red	3	GND	Ground
4	white	4	—	not connected
5	orange	5	Channel A\	Channel A complement
6	white	6	Channel A	Channel A
7	yellow	7	Channel B\	Channel B complement
8	white	8	Channel B	Channel B
9	green	9	Channel I\	Channel I complement
10	white	10	Channel I	Channel I

Table 3-20 Encoder connector X5 – Pin assignment

Accessories		
Suitable strain relief	Retainer	For sockets with strain relief: 1 retainer clip, height 13.5 mm, 3M (3505-8110) For sockets without strain relief: 1 retainer clip, height 7.9 mm, 3M (3505-8010)
	Latch	For sockets with strain relief: 2 pieces, 3M (3505-33B)

Table 3-21 Encoder connector X5 – Accessories

Encoder Cable (275934)	
Cross-section	10 x AWG28, round-jacket, flat cable, pitch 1.27 mm
Length	3 m
Head A	DIN 41651 female, pitch 2.54 mm, 10 poles, with strain relief
Head B	DIN 41651 plug, pitch 2.54 mm, 10 poles, with strain relief

Table 3-22 Encoder Cable

3.3.4.6 Sensor (X6)

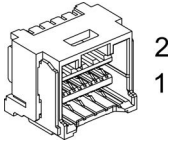

Figure 3-14 Sensor connector X6

X6 Head A Pin	Prefab Cable Color	Head B Pin	Signal	Description
1	white	1	—	not connected
2	brown	2	—	not connected
3	green	3	—	not connected
4	yellow	4	—	not connected
5	grey	5	Clock	Clock (SSI)
			HsDigOUT1	High-speed digital output 1
6	pink	6	Clock\	Clock (SSI) complement
			HsDigOUT1\	High-speed digital output 1 complement
7	blue	7	Data	Data (SSI)
			HsDigIN4	High-speed digital input 4
8	red	8	Data\	Data (SSI) complement
			HsDigIN4\	High-speed digital Input 4 complement
9	black	9	GND	Ground
10 [d]	violet	10	V _{Sensor}	Sensor output voltage (+5 VDC; I _L ≤145 mA)
			V _{DD}	Auxiliary output voltage (+5 VDC; I _L ≤300 mA)

[d] switchable between V_{Sensor} and V_{DD} using switch SW2 on the EvaBo

Table 3-23 Sensor connector X6 – Pin assignment

Sensor Cable 5x2core (520852)		
Cross-section	5 x 2 x 0.14 mm ² , twisted pair, grey	
Length	3 m	
Head A	Plug	Molex CLIK-Mate, dual row, 10 poles (503149-1000)
	Contacts	Molex CLIK-Mate crimp terminals (502579)
Head B	Wire end sleeves 0.14 mm ²	

Table 3-24 Sensor Cable 5x2core

3.3.4.7 Digital I/O (X7)

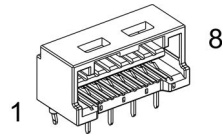

Figure 3-15 Digital I/O connector X7

X7 Head A Pin	Prefab Cable Color	Head B Pin	Signal	Description
1	white	1	DigIN1	Digital input 1
2	brown	2	DigIN2	Digital input 2
3	green	3	DigIN3	Digital input 3
4	yellow	4	DigIN4	Digital input 4
5	grey	5	DigOUT1	Digital output 1
6	pink	6	DigOUT2	Digital output 2
7	blue	7	GND	Ground
8 [d]	red	8	V_{Sensor}	Sensor output voltage (+5 VDC; $I_L \leq 145$ mA)
			V_{DD}	Auxiliary output voltage (+5 VDC; $I_L \leq 300$ mA)

[d] switchable between V_{Sensor} and V_{DD} using switch SW2 on the EvaBo

Table 3-25 Digital I/O connector X7 – Pin assignment

Signal Cable 8core (520853)		
Cross-section	8 x 0.14 mm ² , grey	
Length	3 m	
Head A	Plug	Molex CLIK-Mate, single row, 8 poles (502578-0800)
	Contacts	Molex CLIK-Mate crimp terminals (502579)
Head B	Wire end sleeves 0.14 mm ²	

Table 3-26 Signal Cable 8core

3.3.4.8 Analog I/O (X8)

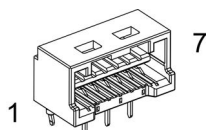

Figure 3-16 Analog I/O connector X8

X8 Head A Pin	Prefab Cable Color	Head B Pin	Signal	Description
1	white	1	AnIN1+	Analog input 1, positive signal
2	brown	2	AnIN1-	Analog input 1, negative signal
3	green	3	AnIN2+	Analog input 2, positive signal
4	yellow	4	AnIN2-	Analog input 2, negative signal
5	grey	5	AnOUT1	Analog output 1
6	pink	6	—	not connected
7	blue	7	GND	Ground

Table 3-27 Analog I/O connector X8 – Pin assignment

Signal Cable 7core (520854)		
Cross-section	7 x 0.14 mm ² , grey	
Length	3 m	
Head A	Plug	Molex CLIK-Mate, single row, 7 poles (502578-0700)
	Contacts	Molex CLIK-Mate crimp terminals (502579)
Head B	Wire end sleeves 0.14 mm ²	

Table 3-28 Signal Cable 7core

3.3.4.9 RS232 (X10)

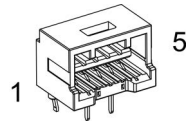

Figure 3-17 RS232 connector X10

X10 Head A Pin	Prefab Cable Color	Head B Pin	Signal	Description
1	white	3	EPOS_RxD	EPOS RS232 receive
2	brown	5	GND	Ground
3	green	2	EPOS_TxD	EPOS RS232 transmit
4	yellow	5	GND	Ground
5	Shield	Housing	Shield	Cable shield

Table 3-29 RS232 connector X10 – Pin assignment

RS232-COM Cable (520856)		
A		B
Cross-section	2 x 2 x 0.14 mm ² , twisted pair, shielded	
Length	3 m	
Head A	Plug	Molex CLIK-Mate, single row, 5 poles (502578-0500)
	Contacts	Molex CLIK-Mate crimp terminals (502579)
Head B	Female D-Sub connector DIN 41652, 9 poles, with mounting screws	

Table 3-30 RS232-COM Cable

3.3.4.10 CAN 1 (X11) & CAN 2 (X12)

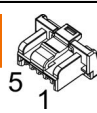
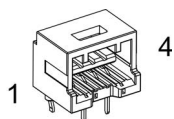

Figure 3-18 CAN 1 connector X11/CAN 2 connector X12

X11/X12 Head A Pin	Prefab Cable Color	520857 Head B Pin	520858 Head B Pin	Signal	Description
1	white	7	1	CAN high	CAN high bus line
2	brown	2	2	CAN low	CAN low bus line
3	green	3	3	GND	Ground
4	Shield	5	4	Shield	Cable shield

Table 3-31 CAN 1 connector X11/CAN 2 connector X12 – Pin assignment

CAN-COM Cable (520857)		
A		B
		
Cross-section	2 x 2 x 0.22 mm ² , twisted pair, shielded	
Length	3 m	
Head A	Plug	Molex CLIK-Mate, single row, 4 poles (502578-0400)
	Contacts	Molex CLIK-Mate crimp terminals (502579)
Head B	Female D-Sub connector DIN 41652, 9 poles, with mounting screws	

Table 3-32 CAN-COM Cable



CAN-CAN Cable (520858)		
A		B
		
Cross-section	2 x 2 x 0.22 mm ² , twisted pair, shielded	
Length	3 m	
Head A	Plug	Molex CLIK-Mate, single row, 4 poles (502578-0400)
	Contacts	Molex CLIK-Mate crimp terminals (502579)
Head B	Plug	Molex CLIK-Mate, single row, 4 poles (502578-0400)
	Contacts	Molex CLIK-Mate crimp terminals (502579)

Table 3-33 CAN-CAN Cable

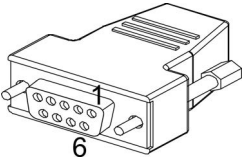
3.3.4.11 USB (X13)



Hot plugging the USB interface may cause hardware damage

If the USB interface is being hot-plugged (connecting while the power supply is on), the possibly high potential differences of the two power supplies of controller and PC/Notebook can lead to damaged hardware.

- Avoid potential differences between the power supply of controller and PC/Notebook or, if possible, balance them.
- Insert the USB connector first, then switch on the power supply of the controller.

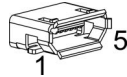

Figure 3-19 USB connector X13

Micro Header Pin	EvaBo Connector Pin	PC's USB Terminal	Signal	Description
A58	X13 5	4	GND	USB ground
A59	X13 2	2	USB_D-	USB Data- (twisted pair with Data+)
A60	X13 1	1	V _{BUS}	USB bus supply voltage input +5 VDC
A61	X13 3	3	USB_D+	USB Data+ (twisted pair with Data-)
—	X13 4	—	ID	not connected

Table 3-34 USB connector X13 – Pin assignment

USB Type A - micro B Cable (403968)	
A	B
	
Cross-section	According to USB 2.0 / USB 3.0 specification
Length	1.5 m
Head A	USB Type "micro B", male
Head B	USB Type "A", male

Table 3-35 USB Type A - micro B Cable

USB	
USB Standard	USB 2.0 / USB 3.0 (full speed)
Max. bus supply voltage	+5.25 VDC
Max. DC data input voltage	-0.5...+3.8 VDC

Table 3-36 USB interface specification

3.3.5 Switch Configuration

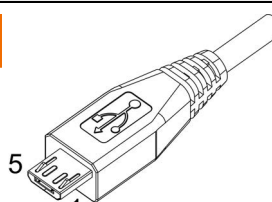
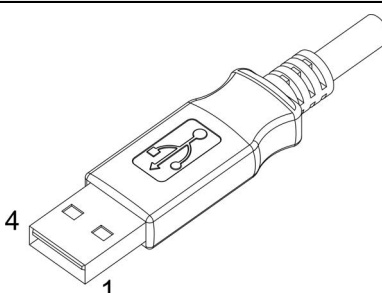
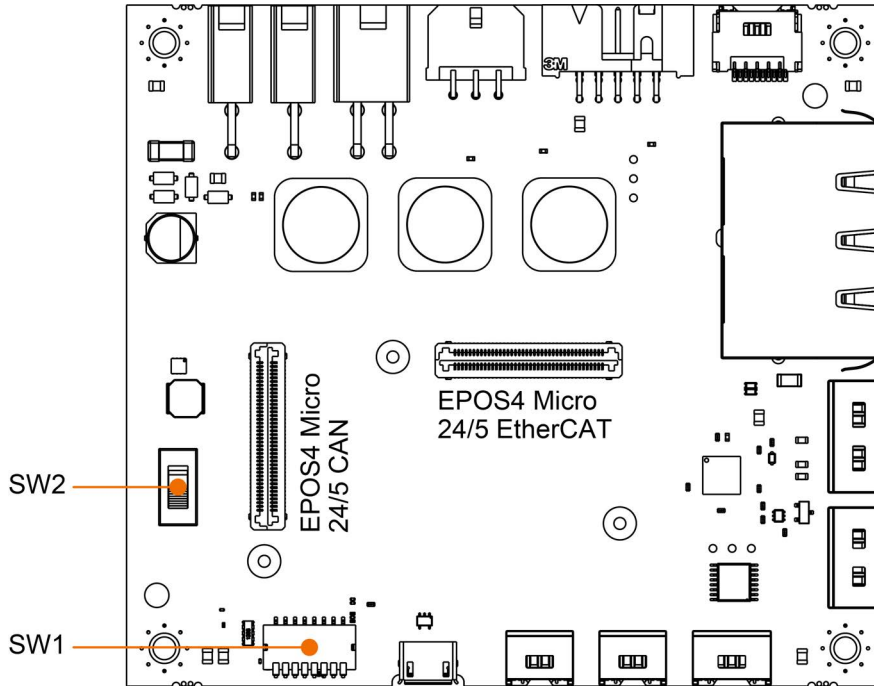

Figure 3-20 EvaBo switches – Location

3.3.5.1 DIP Switch SW1

CAN ID



Setting the ID by means of DIP switches is currently available for CAN only!

The device's identification (subsequently called "ID") is set by means of DIP switches 1...5. The ID (1...31) may be coded using binary code.



Setting the ID by DIP switch SW1

- By setting the DIP switch (1...5) address 0 ("OFF"), the ID may be set by software (object 0x2000 «Node-ID», range 1...127).
- The ID results in the summed values of DIP switch addresses 1 ("ON").
- DIP switches 6...8 do not have any impact on the ID.

Setting	Switch	Binary Code	Valence
 (factory setting)	1	2^0	1
	2	2^1	2
	3	2^2	4
	4	2^3	8
	5	2^4	16

Table 3-37 EvaBo DIP switch SW1 – Binary code values

Continued on next page.

The set ID can be observed by adding the valence of all activated switches. Use the following table as a (non-concluding) guide:







Setting	Switch					ID
	1	2	3	4	5	
 ↑OFF ↓ON	0	0	0	0	0	—
 ↑OFF ↓ON	1	0	0	0	0	1
 ↑OFF ↓ON	0	1	0	0	0	2
 ↑OFF ↓ON	0	0	1	0	0	4
 ↑OFF ↓ON	1	0	1	0	0	5
 ↑OFF ↓ON	0	0	0	1	0	8
 ↑OFF ↓ON	0	0	0	0	1	16
 ↑OFF ↓ON	1	1	1	1	1	31
0 = Switch "OFF" 1 = Switch "ON"						

Table 3-38 EvaBo DIP switch SW1 – Examples

CAN AUTOMATIC BIT RATE DETECTION

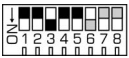
Switch	OFF	ON
6	 ↑OFF ↓ON Automatic bit rate detection deactivated	 ↑OFF ↓ON Automatic bit rate detection activated (factory setting)

Table 3-39 EvaBo DIP switch SW1 – CAN automatic bit rate detection

CAN BUS TERMINATION

Switch	OFF	ON
7	 ↑OFF ↓ON Without bus termination (factory setting)	 ↑OFF ↓ON Bus termination with 120 Ω

Table 3-40 EvaBo DIP switch SW1 – CAN bus termination

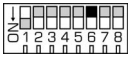
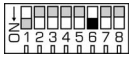
DIGITAL INPUT LEVEL

For details → chapter “3.4.7 Digital I/Os” on page 3-49.

Switch	OFF	ON
8	 <p>Logic level (factory setting)</p>	 <p>PLC level</p>

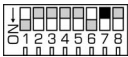
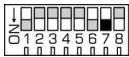
Table 3-41 EvaBo DIP switch SW1 – Digital input level

3.3.5.2 Switch SW2

Using switch SW2, you may select the source of the voltage supply for peripherals and related transceivers. This allows you to check whether the Sensor supply voltage V_{Sensor} provided by the Micro is sufficient for your use application or if you will need to provide an additional voltage source.

Connector		Position “VDD”	Position “ V_{Sensor} ”
		Supply source	
Hall sensor	X4	Sensor supply voltage V_{Sensor}	Sensor supply voltage V_{Sensor}
Encoder	X5	Sensor supply voltage V_{Sensor}	Sensor supply voltage V_{Sensor}
Sensor	X6	Output voltage V_{DD}	Sensor supply voltage V_{Sensor}
Digital I/Os	X7	Output voltage V_{DD}	Sensor supply voltage V_{Sensor}
RS232	X10	Auxiliary supply voltage V_{DD}	Sensor supply voltage V_{Sensor}

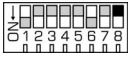
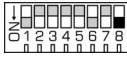
Table 3-42 Voltage outputs – Source

Voltage outputs	
Sensor supply voltage V_{Sensor}	+5 VDC; $I_L \leq 145$ mA; sourced by Micro
Auxiliary supply voltage V_{DD}	+5 VDC; $I_L \leq 300$ mA, sourced by EvaBo

Table 3-43 Voltage outputs – Specifications

3.4 Connection Specifications

The actual connection will depend on the overall configuration of your drive system and the type of motor you will be using. Follow the description in given order and choose the wiring diagram (→ as of page 5-75) that best suits the components you are using.



How to read the following data

The following tables feature, where applicable, connection details for both Micro and EvaBo. Thereby,...

- the column «Micro Header Pin» refers to the header's pin number.
Example: **A19...A24** means header A, pins 16 thru 24
- the column «EvaBo Connector Pin» refers to the connector's pin number.
Example: **X1 | 2** means connector X1, pin 2

For easier legibility, the subsequently used circuit diagrams refer to the Micro. For the EvaBo's circuitry take the second column «EvaBo Connector Pin» into account.

3.4.1 Power Supply

Basically, any power supply may be used provided that it meets the below stated minimum requirements.

Micro Header Pin	EvaBo Connector Pin	Signal	Description
A19...A24**	X1 2	+V _{CC}	Power supply voltage (+10...+24 VDC)
A25**	X1 1	GND	Ground
A27...A32**			

** Connect all pins in respect to the individual pin current rating.

Table 3-44 Power supply – Pin assignment

Power supply requirements	
Output voltage	+V _{CC} 10...24 VDC
Absolute output voltage	min. 8 VDC; max. 28 VDC
Output current	Depending on load <ul style="list-style-type: none"> • continuous max. 1.5 A • short-time (acceleration, <10 s) max. 4.5 A

Table 3-45 Power supply requirements

- 1) Use the formula below to calculate the required voltage under load.
- 2) Choose a power supply according to the calculated voltage. Thereby consider:
 - a) During braking of the load, the power supply must be capable of buffering the recovered kinetic energy (for example, in a capacitor).
 - b) If you are using an electronically stabilized power supply, make sure that the overcurrent protection circuit is configured inoperative within the operating range.

Continued on next page.



The formula already takes the following into account:

- Maximum PWM duty cycle of 90%
- Controller's max. voltage drop of 1 V @ 1.5 A

KNOWN VALUES:

- Operating torque M [mNm]
- Operating speed n [rpm]
- Nominal motor voltage U_N [Volt]
- Motor no-load speed at U_N ; n_o [rpm]
- Speed/torque gradient of the motor $\Delta n/\Delta M$ [rpm/mNm]

SOUGHT VALUE:

- Supply voltage $+V_{CC}$ [Volt]

SOLUTION:

$$V_{CC} \geq \left[\frac{U_N}{n_o} \cdot \left(n + \frac{\Delta n}{\Delta M} \cdot M \right) \cdot \frac{1}{0.9} \right] + 1 [V]$$

3.4.2 Logic Supply



Separate power supply

The logic part of the controller may be supplied by separate supply voltage provided that it meets the below stated minimum requirements.

- *Micro:* The logic supply must be connected separately.
- *EvaBo:* If not supplied separately, the logic supply is internally connected to the power supply.

Micro Header Pin	EvaBo Connector Pin	Signal	Description
A25	X2 1	GND	Ground
A26	X2 2	$+V_c$	Logic supply voltage (+10...+24 VDC)

Table 3-46 Logic supply – Pin assignment

Power supply requirements	
Output voltage	$+V_c$ 10...24 VDC
Absolute supply voltage	min. 8 VDC; max. 28 VDC
Min. output power	P_c min. 3.5 W

Table 3-47 Logic supply requirements

3.4.3 Motor

The EPOS4 is set to drive either maxon DC motors (brushed) or maxon EC motors (brushless).

Micro Header Pin	EvaBo Connector Pin	Signal	Description
A1...A6**	X3 1	Motor (+M)	Motor +
A7...A12**	X3 2	Motor (-M)	Motor -
—	X3 3	—	not connected
—	X3 4	Motor shield	Cable shield

** Connect all pins in respect to the individual pin current rating.

Table 3-48 DC motor – Pin assignment

Micro Header Pin	EvaBo Connector Pin	Signal	Description
A1...A6**	X3 1	Motor winding 1	Winding 1
A7...A12**	X3 2	Motor winding 2	Winding 2
A13...A18**	X3 3	Motor winding 3	Winding 3
—	X3 4	Motor shield	Cable shield

** Connect all pins in respect to the individual pin current rating.

Table 3-49 EC motor – Pin assignment

3.4.4 Hall Sensor

Micro Header Pin	EvaBo Connector Pin	Signal	Description
A27...A32	X4 4	GND	Ground
A33	X4 1	Hall sensor 1	Hall sensor 1 input
A35	X4 2	Hall sensor 2	Hall sensor 2 input
A37	X4 3	Hall sensor 3	Hall sensor 3 input
A39	X4 5	V_{Sensor}	Sensor supply voltage (+5 VDC; $I_L \leq 145 \text{ mA}$)
—	X4 6	Hall shield	Cable shield

Table 3-50 Hall sensor – Pin assignment

Hall sensor	
Sensor supply voltage (V_{Sensor})	+5 VDC
Input voltage	0...24 VDC
Max. input voltage	+24 VDC
Logic 0	typically <0.8 V
Logic 1	typically >2.0 V
Internal pull-up resistor	10 k Ω (referenced to +5.45 V)

Table 3-51 Hall sensor specification

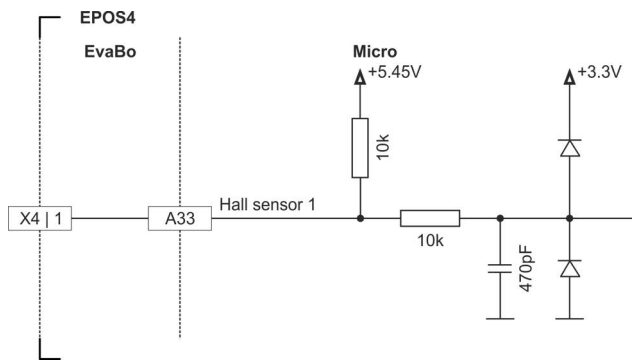

Figure 3-21 Hall sensor 1 input circuit (analogously valid for Hall sensors 2 & 3)

3.4.5 Encoder



Best practice

- *Differential signals offer good resistance against electrical interference. Therefore, **we recommend using a differential scheme**. Nevertheless, the controller supports both schemes – differential and single-ended (unsymmetrical).*
- *For best performance, **we strongly recommend using encoders with a line driver**. Otherwise, limitations may apply due to slow switching edges.*
- *Even though 2-channel will do, **we strongly recommend to use only 3-channel versions**.*

Micro Header Pin	EvaBo Connector Pin	Signal	Description
A27...A32	X5 3	GND	Ground
A34	X5 6	Channel A	Digital incremental encoder channel A
A36	X5 5	Channel A \bar{A}	Digital incremental encoder channel A complement
A38	X5 8	Channel B	Digital incremental encoder channel B
A39	X5 2	V_{Sensor}	Sensor supply voltage (+5 VDC; $I_L \leq 145$ mA)
A40	X5 7	Channel B \bar{B}	Digital incremental encoder channel B complement
A42	X5 10	Channel I	Digital incremental encoder channel I
A44	X5 9	Channel I \bar{I}	Digital incremental encoder channel I complement

Table 3-52 Encoder – Pin assignment

Encoder (differential)	
Sensor supply voltage (V_{Sensor})	+5 VDC
Min. differential input voltage	± 200 mV
Max. input voltage	± 12 VDC
Line receiver (internal)	EIA RS422 standard
Max. input frequency	6.25 MHz

Table 3-53 Differential encoder specification

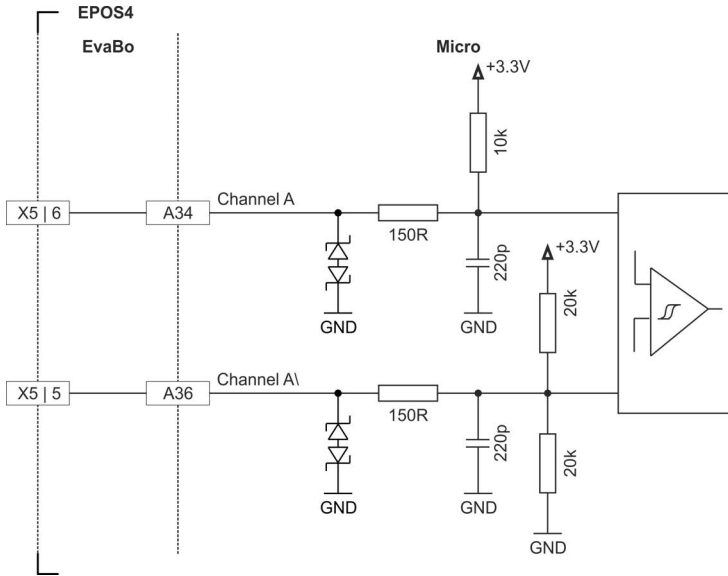

Figure 3-22 Encoder input circuit Ch A “differential” (analogously valid for Ch B & Ch I)

Encoder (single-ended)		
Sensor supply voltage (V_{Sensor})	+5 VDC	
Input voltage	0...5 VDC	
Max. input voltage	± 12 VDC	
Logic 0	<1.0 V	
Logic 1	>2.4 V	
Input high current	I_{IH} = typically +250 μA @ 5 V	
Input low current	I_{IL} = typically -330 μA @ 0 V	
Max. input frequency	Push-pull	6.25 MHz
	Open collector	40 kHz (internal pull-up only) 150 kHz (additional external 3k3 pull-up)

Table 3-54 Single-ended encoder specification

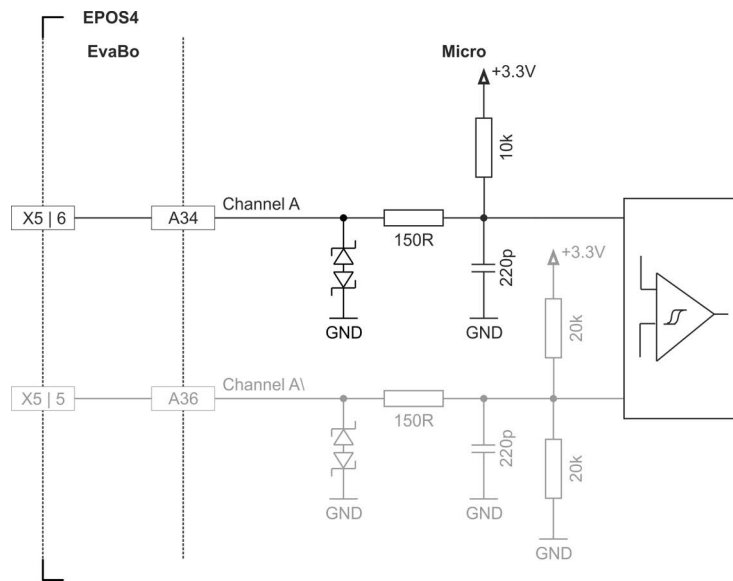

Figure 3-23 Encoder input circuit Ch A “single-ended” (analogously valid for Ch B & Ch I)

3.4.6 Sensor

3.4.6.1 SSI Absolute Encoder

Micro Header Pin	EvaBo Connector Pin	Signal	Description
A39	X6 10 [d]	V_{Sensor}	Sensor output voltage (+5 VDC; $I_L \leq 145$ mA)
		V_{DD}	Auxiliary output voltage (+5 VDC; $I_L \leq 300$ mA)
A53	X6 7	Data	Data (SSI)
—	X6 8	Data\	Data (SSI) complement
A55	X6 5	Clock	Clock (SSI)
—	X6 6	Clock\	Clock (SSI) complement
A57	X6 9	GND	Ground

[d] switchable between V_{Sensor} and V_{DD} using switch SW2 on the EvaBo

Table 3-55 SSI absolute encoder – Pin assignment

SSI absolute encoder (Micro)	
Auxiliary output voltage	+5 VDC
Max. supply current	V_{Sensor} 145 mA
Input voltage	0...3.3 VDC
Max. input voltage	3.3 VDC
High-level input voltage	>2.0 VDC
Low-level input voltage	<0.8 VDC
High-level output voltage	>2.4 VDC
Low-level output voltage	<0.4 VDC

Table 3-56 SSI absolute encoder specification (Micro)

SSI absolute encoder (EvaBo)	
Auxiliary output voltage	+5 VDC
Max. supply current	V_{DD} 300 mA / V_{Sensor} 145 mA
Min. differential input voltage	± 200 mV
Min. differential output voltage	± 1.8 V @ external load $R=54 \Omega$
Max. output current	40 mA
Line receiver (internal)	EIA RS422 standard
Encoder input/output frequency	0.4... 2 MHz

Table 3-57 SSI absolute encoder specification (EvaBo)

Continued on next page.

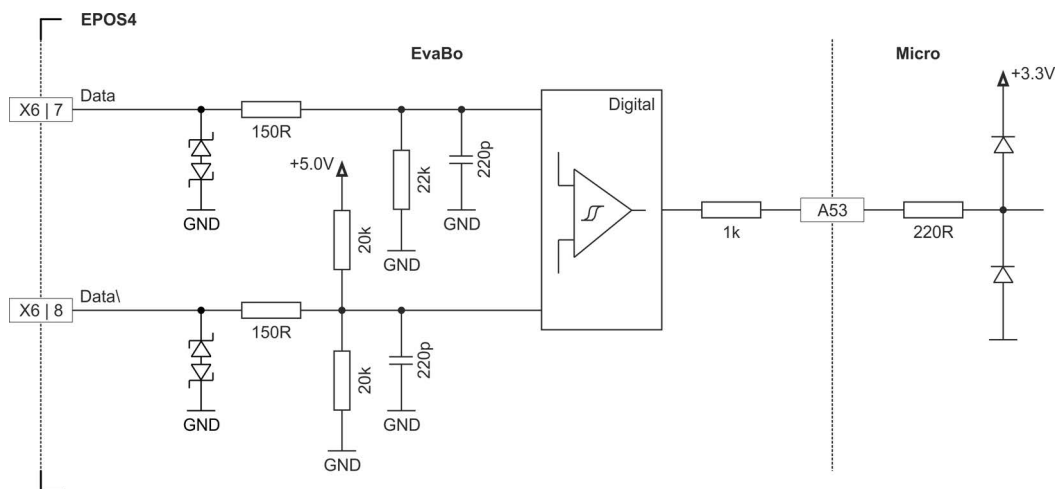

Figure 3-24 SSI absolute encoder data input

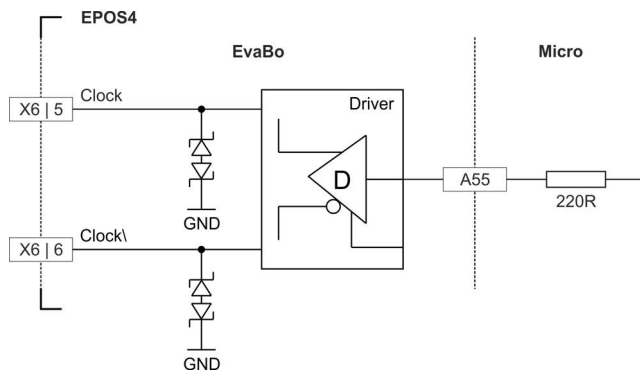

Figure 3-25 SSI absolute encoder clock output

3.4.6.2 High-speed Digital I/Os

Alternatively, the sensor interface can be used for high-speed digital I/O operation.

Micro Header Pin	EvaBo Connector Pin	Signal	Description
A39	X6 10 [d]	V_{Sensor}	Sensor output voltage (+5 VDC; $I_L \leq 145$ mA)
		V_{DD}	Auxiliary output voltage (+5 VDC; $I_L \leq 300$ mA)
A53	X6 7	HsDigIN4	High-speed digital input 4
—	X6 8	HsDigIN4\	High-speed digital input 4 complement
A55	X6 5	HsDigOUT1	High-speed digital output 1
—	X6 6	HsDigOUT1\	High-speed digital output 1 complement
A57	X6 9	GND	Ground
—	X6 1	—	not connected
—	X6 2	—	not connected
—	X6 3	—	not connected
—	X6 4	—	not connected

[d] switchable between V_{Sensor} and V_{DD} using switch SW2 on the EvaBo

Table 3-58 High-speed digital I/Os – Pin assignment

High-speed digital input 4 (differential)	
Max. input voltage	± 12 VDC
Min. differential input voltage	± 200 mV
Line receiver (internal)	EIA RS422 standard
Max. input frequency	6.25 MHz

Table 3-59 Differential high-speed digital input specification

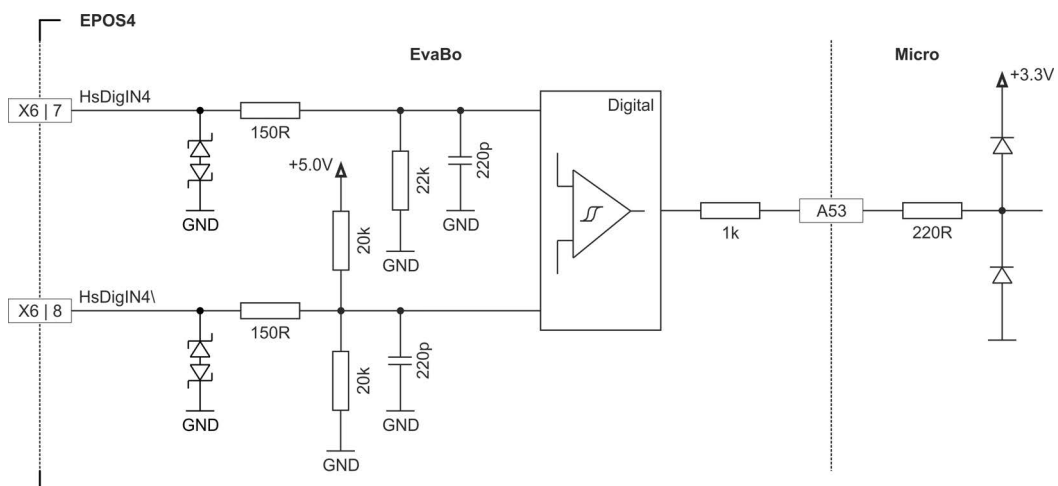

Figure 3-26 HsDigIN4 circuit “differential”

High-speed digital input 4 (Micro, single-ended)	
Input voltage	0...3.3 VDC
Max. input voltage	3.3 VDC
Logic 0	<0.8 V
Logic 1	>2.0 V
Max. input frequency	6.25 MHz

Table 3-60 Single-ended high-speed digital input specification (Micro)

High-speed digital input 4 (EvaBo, single-ended)	
Input voltage	0...5 VDC
Max. input voltage	±12 VDC
Logic 0	<1.0 V
Logic 1	>3.0 V
Max. input frequency	6.25 MHz

Table 3-61 Single-ended high-speed digital input specification (EvaBo)

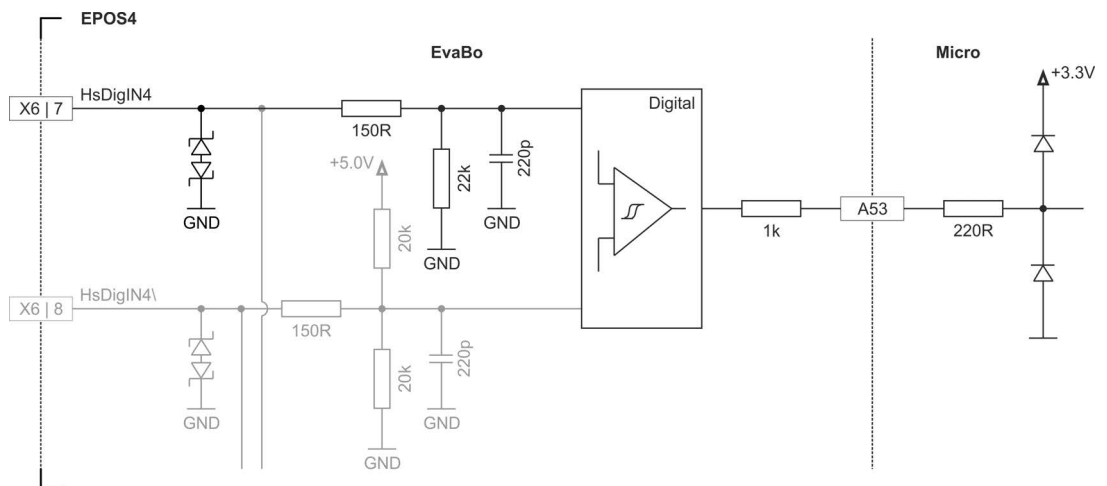

Figure 3-27 HsDigIN4 circuit "single-ended"

High-speed digital output 1 (Micro, single-ended)	
High-level output voltage	>2.4 VDC
Low-level output voltage	<0.4 VDC
Max. output current	≤2 mA

Table 3-62 High-speed digital output specification (EvaBo)

Continued on next page.

High-speed digital output 1 (EvaBo, differential)	
Min. differential output voltage	$\pm 1.8 \text{ V @ external load } R=54 \Omega$
Max. output current	40 mA
Line transceiver (internal)	EIA RS422 standard
Max. output frequency	6.25 MHz

Table 3-63 High-speed digital output specification (EvaBo)

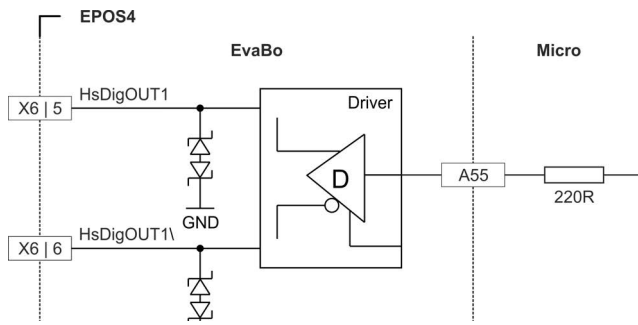

Figure 3-28 HsDigOUT1 output circuit

3.4.7 Digital I/Os

3.4.7.1 Digital Inputs Micro

Micro Header Pin	Signal	Description
A39	V_{Sensor}	Sensor output voltage (+5 VDC; $I_L \leq 145$ mA)
A41	DigIN1	Digital input 1
A43	DigIN2	Digital input 2
A45	DigIN3	Digital input 3
A47	DigIN4	Digital input 4
A57	GND	Ground

Table 3-64 Digital inputs – Pin assignment – Micro

Digital inputs 1...4 (Micro)	
Input voltage	0...36 VDC
Max. input voltage	± 36 VDC
Logic 0	<0.8 V
Logic 1	>2.1 V
Input resistance	typically 47 k Ω (<3.3 V) typically 37.5 k Ω (@ 5 V) typically 25.5 k Ω (@ 24 V)
Input current at logic 1	typically 135 μ A @ +5 VDC
Switching delay	<300 μ s

Table 3-65 Digital input specification – Micro

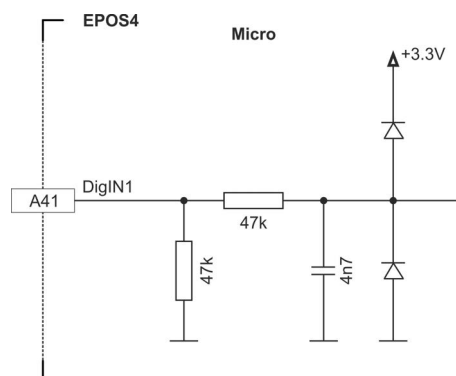

Figure 3-29 DigIN1 circuit (analogously valid for DigIN2...4) – Micro

3.4.7.2 Digital Inputs EvaBo

EvaBo Connector Pin	Signal	Description
X7 1	DigIN1	Digital input 1
X7 2	DigIN2	Digital input 2
X7 3	DigIN3	Digital input 3
X7 4	DigIN4	Digital input 4
X7 7	GND	Ground
X7 8 [d]	V_{Sensor}	Sensor output voltage (+5 VDC; $I_L \leq 145$ mA)
	V_{DD}	Auxiliary output voltage (+5 VDC; $I_L \leq 300$ mA)

[d] switchable between V_{Sensor} and V_{DD} using switch SW2 on the EvaBo

Table 3-66 Digital inputs – Pin assignment – EvaBo

Digital inputs 1...4 (EvaBo / Logic level setting)	
Input voltage	0...30 VDC
Max. input voltage	± 30 VDC
Logic 0	<0.8 V
Logic 1	>2.0 V
Input current at logic 1	250 μA @ 5 VDC
Switching delay	<300 μs @ 5 VDC

Table 3-67 Digital input specification – Logic level setting

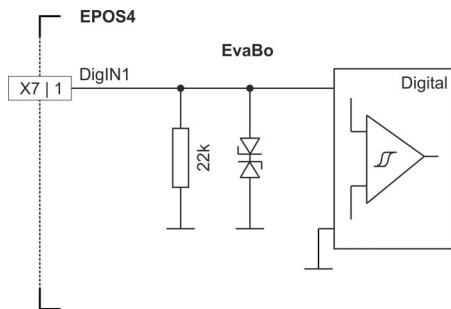

Figure 3-30 DigIN1 circuit (analogously valid for DigIN2...4) – EvaBo / Logic level setting

Continued on next page.

Digital inputs 1...4 (EvaBo / PLC level setting)	
Input voltage	0...30 VDC
Max. input voltage	±30 VDC
Logic 0	<5.5 V
Logic 1	>9 V
Input current at logic 1	>2 mA @ 9 VDC typically 3.5 mA @ 24 VDC
Switching delay	<300 μs @ 24 VDC

Table 3-68 Digital input specification – PLC level setting

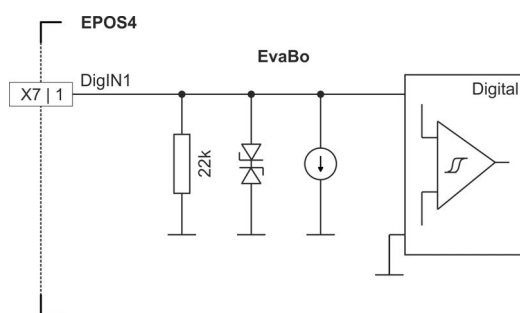

Figure 3-31 DigIN1 circuit (analogously valid for DigIN2...4) – EvaBo / PLC level setting

3.4.7.3 Digital Outputs

Micro Header Pin	EvaBo Connector Pin	Signal	Description
A49	X7 5	DigOut1	Digital output 1
A51	X7 6	DigOut2	Digital output 2
A57	X7 7	GND	Ground

Table 3-69 Digital outputs – Pin assignment – Micro

Digital outputs 1...2	
Circuit	Open drain (internal pull-up resistor 2k2 and diode to +5.45 VDC)

Table 3-70 Digital output specification

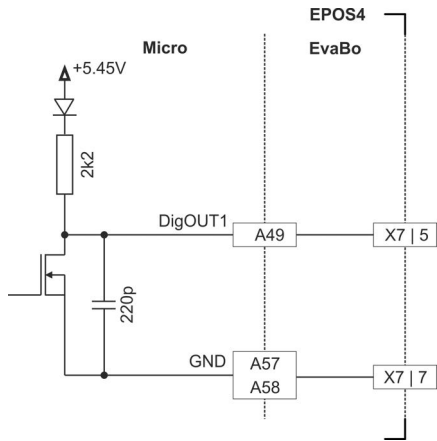

Figure 3-32 DigOUT1 circuit (analogously valid for DigOUT2)

Continued on next page.

3.4.8 Analog I/Os

Micro Header Pin	EvaBo Connector Pin	Signal	Description
A46	X8 1	AnIN1+	Analog input 1, positive signal
A48	X8 2	AnIN1-	Analog input 1, negative signal
A50	X8 3	AnIN2+	Analog input 2, positive signal
A52	X8 4	AnIN2-	Analog input 2, negative signal
A54	X8 5	AnOUT1	Analog output 1
A56	X8 7	GND	Ground
A57			

Table 3-73 Analog I/Os – Pin assignment

Analog input 1...2	
Input voltage	±10 VDC (differential)
Max. input voltage	±24 VDC
Common mode voltage	-5...+10 VDC (referenced to GND)
Input resistance	80 kΩ (differential) 65 kΩ (referenced to GND)
A/D converter	12-bit
Resolution	5.64 mV
Bandwidth	10 kHz

Table 3-74 Analog input specification

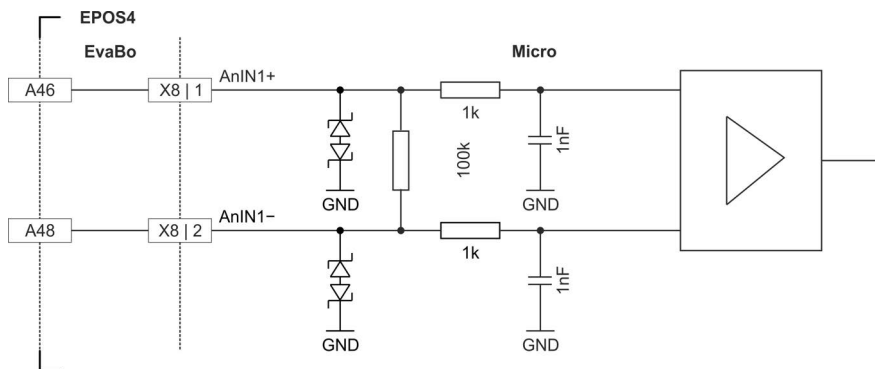

Figure 3-35 AnIN1 circuit (analogously valid for AnIN2)

Continued on next page.

Analog output 1	
Output voltage	±4 VDC
D/A converter	12-bit
Resolution	2.42 mV
Refresh rate	2.5 kHz
Analog bandwidth of output amplifier	25 kHz
Max. capacitive load	300 nF Note: The increase rate is limited in proportion to the capacitive load (e.g. 5 V/ms @ 300 nF)
Max. output current limit	1 mA

Table 3-75 Analog output specification

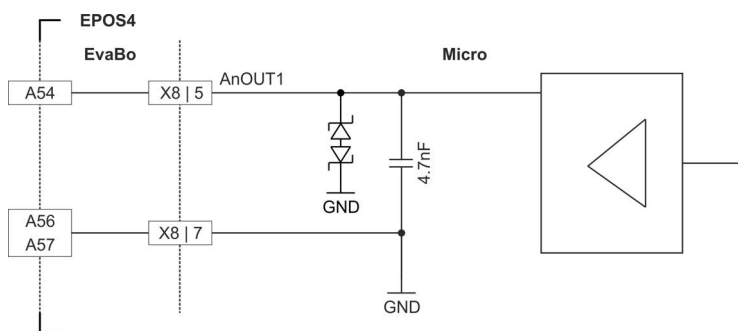

Figure 3-36 AnOUT1 circuit

3.4.9 Serial Communication Interface (SCI) / RS232

The SCI is a two-wire asynchronous serial port, commonly known as a UART. The SCI modules support digital communication between the CPU and other asynchronous peripherals that use the standard non-return-to-zero (NRZ) format.

A common use of the Micro's SCI is to build an RS232 interface by wiring it to an RS232 transceiver. Alternatively, using the EvaBo does not require an external transceiver.



Bit rate settings

- Consider the master's maximal bite rate.
- The standard bit rate setting (factory setting) is 115'200 bit/s.

3.4.9.1 Micro

Micro Header Pin	Signal	Description
A75...A76	GND	Ground
A77	DSP_RxD	Serial communication interface receive (UART)
A78	DSP_TxD	Serial communication interface transmit (UART)

Table 3-76 SCI – Pin assignment

Serial Communication Interface (SCI)	
Input voltage	0...3.3 VDC
Max. input voltage	5 VDC
High-level input voltage	>2.0 VDC
Low-level input voltage	<0.8 VDC
High-level output voltage	>2.4 VDC
Low-level output voltage	<0.4 VDC
Series resistance (both lines)	10 kΩ
Max. bit rate	115'200 bit/s
Data format	NRZ (non-return-to-zero)

Table 3-77 SCI specification

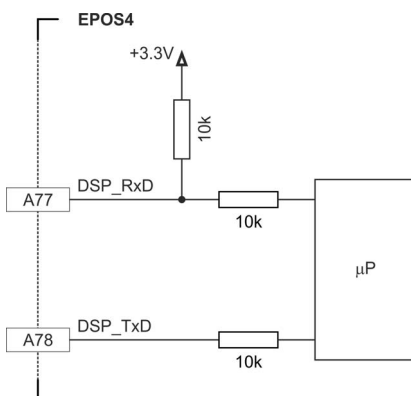

Figure 3-37 SCI circuit

3.4.9.2 EvaBo

EvaBo Connector Pin	Signal	Description
X10 1	EPOS_RxD	EPOS RS232 receive
X10 2	GND	Ground
X10 3	EPOS_TxD	EPOS RS232 transmit
X10 4	GND	Ground
X10 5	Shield	Cable shield

Table 3-78 RS232 – Pin assignment

RS232 Interface	
Max. input voltage	±30 VDC
Output voltage	typically ±9 V @ 3 kΩ to GND
Max. bit rate	115'200 bit/s
RS232 transceiver	EIA RS232 standard

Table 3-79 RS232 interface specification

3.4.10 CAN Interface / ID Setting

3.4.10.1 Connection

The EPOS4 is specially designed being commanded and controlled via a Controller Area Network (CAN), a highly efficient data bus very common in all fields of automation and motion control. It is preferably used as a slave node in the CANopen network.

Micro Header Pin	EvaBo Connector Pin	Signal	Description
A75...A76	X11 3 X12 3	GND	Ground
A79	X11 1 X12 1	CAN high	CAN high bus line
A80	X11 2 X12 2	CAN low	CAN low bus line
—	X11 4 X12 4	Shield	Cable shield

Table 3-80 CAN bus line / CAN 1 / CAN 2 – Pin assignment

CAN interface		
Standard	ISO 11898-2:2003	
Max. bit rate	1 Mbit/s	
Max. number of CAN nodes	Micro	127/63 (via software/hardware setting)
	EvaBo	127/31 (via software/hardware setting)
Protocol	CiA 301 version 4.2.0	
Node-ID setting	Micro	By external wiring or software
	EvaBo	By DIP switch or software

Table 3-81 CAN interface specification



Note

- Consider the CAN master's maximal bit rate.
- The standard bit rate setting (factory setting) is 1 Mbit/s. For the EvaBo, automatic bit rate detection is set.
- Use 120 Ω termination resistor at both ends of the CAN bus.
- For detailed CAN information see separate document →«EPOS4 Communication Guide».

3.4.10.2 Configuration

The device's identification (subsequently called "ID") can be set by different means:

- For configuration on the **EvaBo** → "Switch Configuration" on page 3-34.
- For configuration on the **Micro**, the ID is set using the input lines ID1...ID6. The ID (1...63) may be coded using binary code.

Micro Header Pin	Signal	Description	Binary Code	Valence
A63	GND	Ground		
A65	ID 1	CAN ID 1	2 ⁰	1
A66	ID 5	CAN ID 5	2 ⁴	16
A67	ID 2	CAN ID 2	2 ¹	2
A68	ID 6	CAN ID 6	2 ⁵	32
A71	ID 3	CAN ID 3	2 ²	4
A73	ID 4	CAN ID 4	2 ³	8

Table 3-82 ID – Pin assignment

CAN ID	
Max. input voltage	3.3 VDC
Logic 1	connected to GND
Logic 0	not connected

Table 3-83 CAN ID specification



Important

The internal circuit of the ID pins (A65...A68, A71, A73) is based on an analog voltage measurement. Ensure a proper ground connection (0.0 V) when Logic 1 state is intended and a high impedance for Logic 0 state.

Continued on next page.

The set ID can be observed by adding the valences of all inputs connected externally to GND. Use the following table as a (non-concluding) guide:

CAN ID						ID
1	2	3	4	5	6	
0*	0	0	0	0	0	—
1**	0	0	0	0	0	1
0	1	0	0	0	0	2
0	0	1	0	0	0	4
1	0	1	0	0	0	5
0	0	0	1	0	0	8
0	0	0	0	1	0	16
1	1	1	1	1	1	31
1	1	1	1	1	1	63

0* = ID input line not connected 1** = ID input line externally connected to GND

Table 3-84 ID – Examples



Setting the ID by means of «EPOS Studio»

- The ID may be set by software (changing object 0x2000 «Node-ID», range 1...127).
- The ID set by software is valid if the ID is set to “0” (none of the ID input lines connected).

CAN AUTOMATIC BIT RATE DETECTION

With this function, the CANopen interface can be put in a “listen only” mode. For further details see separate document → «EPOS4 Firmware Specification». Automatic bit rate detection is activated when the input line is externally connected to GND.

Bit rate detection	
Auto Bit Rate	Pin A72
GND	Pin A75
Max. input voltage	3.3 VDC
Logic 1	connected to GND
Logic 0	not connected

Table 3-85 Bit rate detection specification

3.5 Status Indicators

The EPOS4 features three sets of LED indicators to display the device condition.

B Device Status; the LEDs display the device's operation status and error conditions

For detailed information see separate document →«EPOS4 Firmware Specification».

Micro

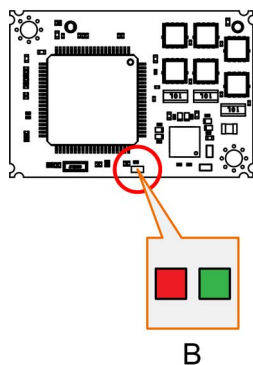

Figure 3-38 LEDs – Location

3.5.1 Device Status

The LEDs (→Figure 3-38; **B**) display the actual status and possible errors of the EPOS4:

- Green LED shows the status
- Red LED indicates errors

LED		Description
Green	Red	
Slow	OFF	Power stage is disabled. The EPOS4 is in status... <ul style="list-style-type: none"> • “Switch ON Disabled” • “Ready to Switch ON” • “Switched ON”
ON	OFF	Power stage is enabled. The EPOS4 is in status... <ul style="list-style-type: none"> • “Operation Enable” • “Quick Stop Active”
OFF	ON	FAULT state. The EPOS4 is in status... <ul style="list-style-type: none"> • “Fault”
ON	ON	Power stage is enabled. The EPOS4 is in temporary status... <ul style="list-style-type: none"> • “Fault Reaction Active”
Flash	ON	No valid firmware or firmware download in progress
Flash = flashing (≈0.9 s OFF/≈0.1 s ON)		
Slow = slow blinking (≈1 Hz)		

Table 3-86 Device Status LEDs

••page intentionally left blank••

4 MOTHERBOARD DESIGN GUIDE

The «Motherboard Design Guide» provides helpful information on integrating the Micro on a printed circuit board. It contains recommendations for the motherboard layout and specifies external components that may be required, pin assignments, and connection examples.



CAUTION

Dangerous Action

Errors in implementing the design can result in serious injury!

- Only proceed if you are skilled in electronics design!
- Designing a printed circuit board requires special skills and knowledge and may only be performed by experienced electronic developers!
- This quick guide is only intended as an aid, does not make any claim to completeness, and will not automatically result in a functional component!



Get help

If you are not trained in the design and development of printed circuit boards, you will need additional support for this point. maxon will be happy to provide you with a quote for designing and manufacturing a motherboard for your specific application.

4.1 Requirements for Components of Third-party Suppliers



Best practice

For references and recommended components consult →Table 4-87.

4.1.1 Terminal/Socket Combo Strip

For implementation of the Micro, a terminal/socket combo strip is required.

4.1.2 Spacers

For implementation of the Micro, two 5 mm long spacers with M2 threads are required. For respective matching types, see →“Recommended Components and Manufacturers” on page 4-70, for their locations and footprint see →Figure 4-48 on page 4-74.

4.1.3 Supply Voltage

To protect the Micro, we recommend using an external circuit breaker, a TVS diode, and a capacitor in the voltage supply line. In this regard, please note the following recommendations:

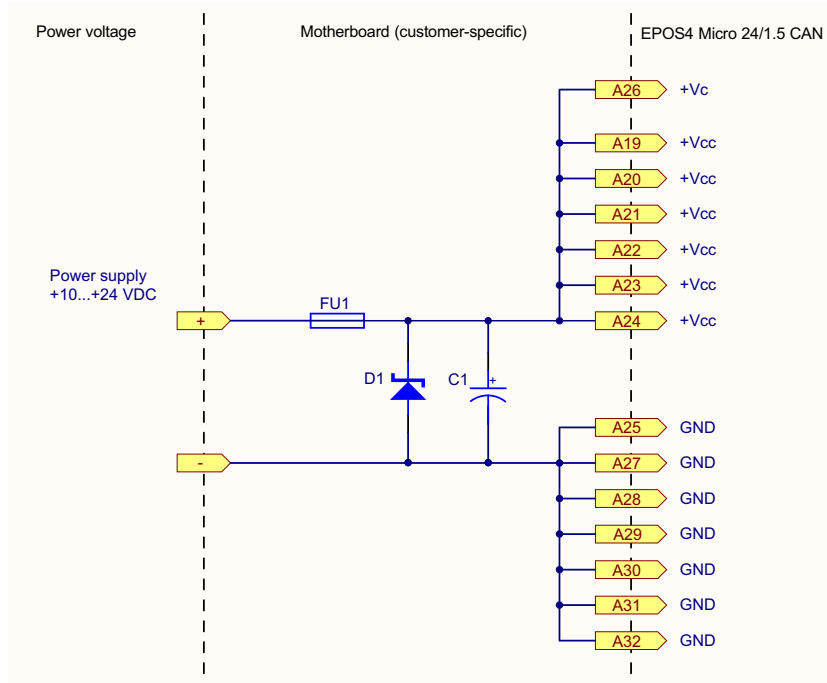

Figure 4-39 Wiring of power supply

INPUT FUSE (FU1)

An input fuse (FU1) is necessary in order to provide reverse polarity protection. Together with an unipolar TVS diode (D1), this prevents current from flowing in the wrong direction.

TVS DIODE (D1)

To protect against overvoltage resulting from voltage transients, we recommend to connect a TVS (transient voltage suppressor) diode (D1) to the voltage supply line.

CAPACITOR (C1)

The function of the Module does not necessarily require the use of an external capacitor. Nevertheless, to further reduce voltage ripple or to buffer feedback currents (typically present during motor deceleration), an electrolytic capacitor (C1) can be connected to the voltage supply line. Use of an electrolytic capacitor is also recommended to avoid oscillations caused by supply cable inductance or by the Module's built-in capacitors that could lead to a voltage overshoot at power plug-in.

4.1.4 Logic Supply Voltage

The Micro features a logic supply voltage input. Its voltage range is 10...24 V and must be either sourced separately or by the power supply voltage.

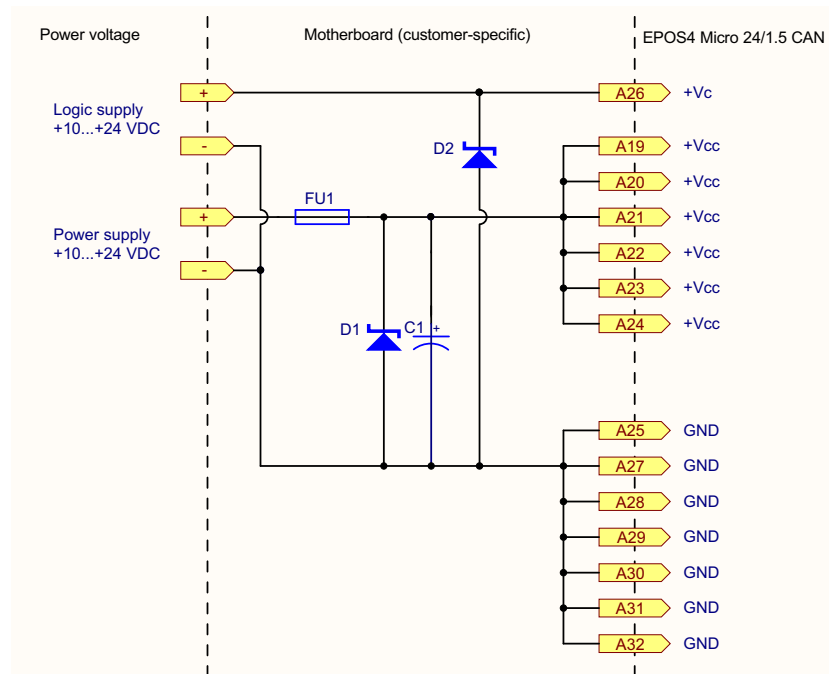

Figure 4-40 Wiring of logic supply

TVS DIODE (D2)

If the logic supply voltage is sourced separately, a transient voltage suppressor diode (D2) at the logic supply voltage input can be connected to protect the Micro against overvoltage.

4.1.5 Motor Cables and Motor Chokes

The Micro is not equipped with internal motor chokes.

The majority of motors and applications do not require additional chokes. However, in case of high supply voltage with very low terminal inductance, the ripple of the motor current can reach an unacceptably high value. This causes the motor to heat up unnecessarily and causes instable control behavior. The minimum terminal inductance required per phase can be calculated using the following formula:

$$L_{Phase} \geq \frac{1}{2} \cdot \left(\frac{V_{CC}}{6 \cdot f_{PWM} \cdot I_N} - (0.3 \cdot L_{Motor}) \right)$$

$L_{Phase}[H]$	Additional external inductance per phase
$V_{CC}[V]$	Operating voltage +V _{CC}
$f_{PWM}[Hz]$	Switching frequency of the power stage = 50'000 Hz
$I_N[A]$	Nominal current of the motor (→line 6 in the maxon catalog)
$L_{Motor}[H]$	Terminal inductance of the motor (→line 11 in the maxon catalog)

If the result of the calculation is negative, no additional chokes are necessary. Nevertheless, the use of chokes in combination with additional filter components can be useful to reduce the emission of electromagnetic interference.

An additional choke must feature electromagnetic shielding, an adequate saturation current, minimal losses, and a nominal current greater than the continuous current of the motor. The below wiring example refers to an additional inductance of 2.2 µH or 33 µH. If a different additional inductance is required, also the filter components must be adapted accordingly. Should you need further help with the filter design, contact maxon Support at →<http://support.maxongroup.com>.

Continued on next page.

Example 1

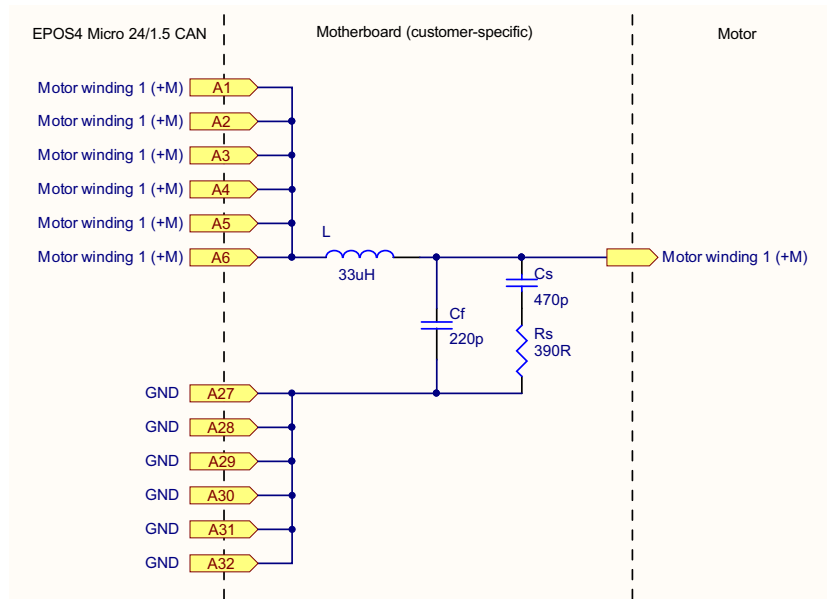

Example 2

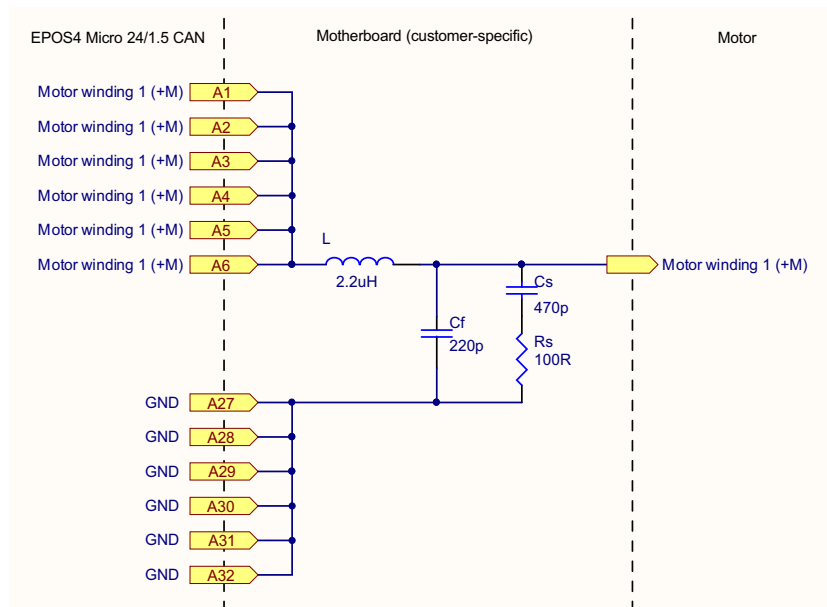

Figure 4-41 Wiring of motor winding 1 (analogously valid also for motor windings 2 & 3)

4.1.6 RS232 Transceiver

If you intend to use an RS232 interface, an external transceiver is necessary.

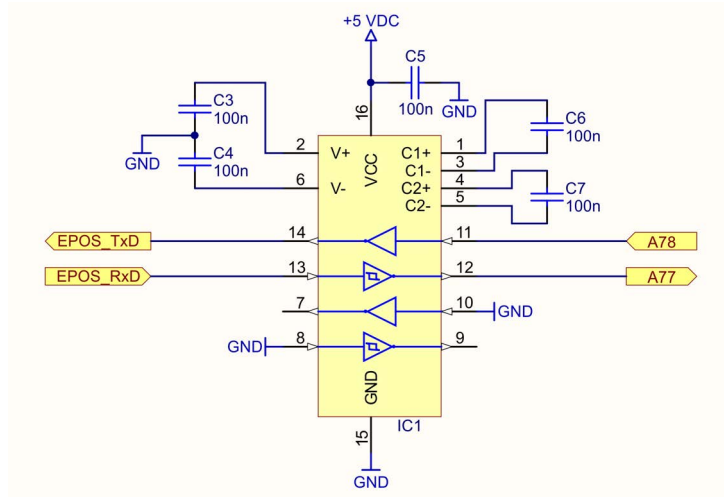

Figure 4-42 Wiring of RS232 transceiver

4.1.7 EIA RS422 Standard for High Speed I/Os and SSI Sensor

If you intend to use an EIA RS422 standard (line driver) for the High Speed I/Os and the SSI sensor, an external RS422 transceiver is necessary.

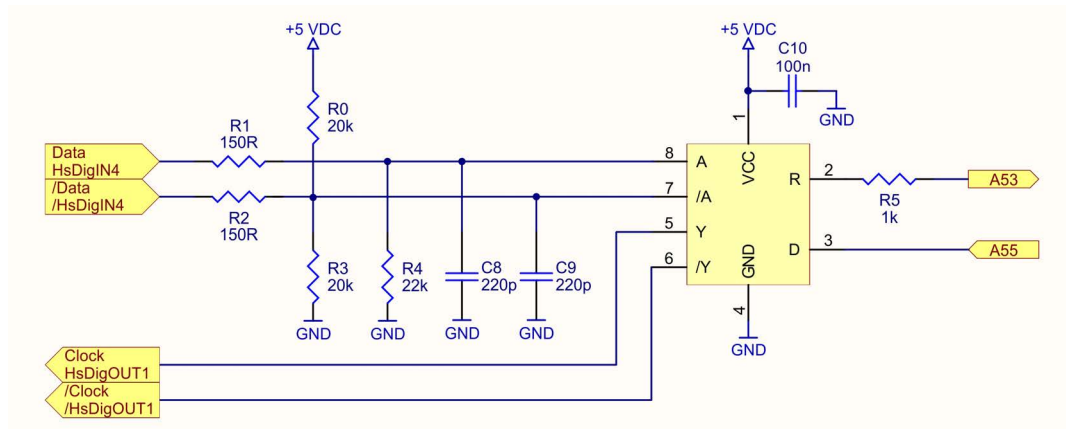

Figure 4-43 Wiring of RS422 transceiver

4.1.8 ESD Protection

The Module does not feature its own ESD protection circuitry. ESD protection must be provided by the motherboard that holds the USB port to which the protective circuitry must be located as close as possible.

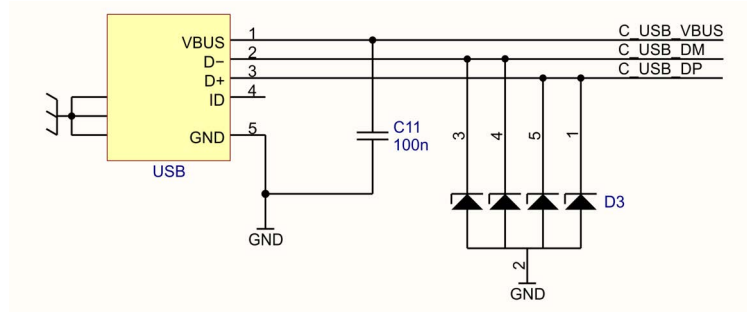

Figure 4-44 USB protection circuitry

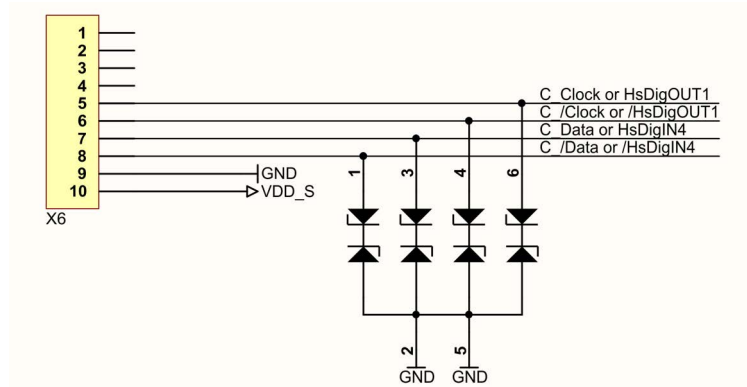

Figure 4-45 High-speed digital input/output and sensor protection circuitry

4.1.9 Recommended Components and Manufacturers

Recommended components																	
Terminal/socket strip	Dual row terminal/socket combo strip, 0.5 mm pitch 40 poles, 2 rows: • maxon (677324) • Samtec (LSHM-140-02.5-L-DV-A-N-K-TR)																
Spacer	2 spacers Ø4.3 x 5 mm, M2 thread • Würth (9774050243) (9774050243R)																
Fuse (FU1)	• Littelfuse 157 Series, Fuse 10 A, 26.46 A ² sec (0157010)																
TVS Diode (D1; D2)	<table border="0"> <tr> <td>• Vishay SMF30A</td> <td>$U_R = 30 \text{ V}, U_{BR} = 33.3 \dots 36.8 \text{ V @ } 1 \text{ mA}, U_C = 48.4 \text{ V @ } 4.1 \text{ A}$</td> </tr> <tr> <td>• Littelfuse SMF30A</td> <td>$U_R = 30 \text{ V}, U_{BR} = 33.3 \dots 36.8 \text{ V @ } 1 \text{ mA}, U_C = 48.4 \text{ V @ } 4.1 \text{ A}$</td> </tr> <tr> <td>• NXP PTVS30VS1UR</td> <td>$U_R = 30 \text{ V}, U_{BR} = 33.3 \dots 36.8 \text{ V @ } 1 \text{ mA}, U_C = 48.4 \text{ V @ } 8.3 \text{ A}$</td> </tr> </table>	• Vishay SMF30A	$U_R = 30 \text{ V}, U_{BR} = 33.3 \dots 36.8 \text{ V @ } 1 \text{ mA}, U_C = 48.4 \text{ V @ } 4.1 \text{ A}$	• Littelfuse SMF30A	$U_R = 30 \text{ V}, U_{BR} = 33.3 \dots 36.8 \text{ V @ } 1 \text{ mA}, U_C = 48.4 \text{ V @ } 4.1 \text{ A}$	• NXP PTVS30VS1UR	$U_R = 30 \text{ V}, U_{BR} = 33.3 \dots 36.8 \text{ V @ } 1 \text{ mA}, U_C = 48.4 \text{ V @ } 8.3 \text{ A}$										
• Vishay SMF30A	$U_R = 30 \text{ V}, U_{BR} = 33.3 \dots 36.8 \text{ V @ } 1 \text{ mA}, U_C = 48.4 \text{ V @ } 4.1 \text{ A}$																
• Littelfuse SMF30A	$U_R = 30 \text{ V}, U_{BR} = 33.3 \dots 36.8 \text{ V @ } 1 \text{ mA}, U_C = 48.4 \text{ V @ } 4.1 \text{ A}$																
• NXP PTVS30VS1UR	$U_R = 30 \text{ V}, U_{BR} = 33.3 \dots 36.8 \text{ V @ } 1 \text{ mA}, U_C = 48.4 \text{ V @ } 8.3 \text{ A}$																
Capacitor (C1)	<p>The ripple current load for C1 depends on the motor's operating point and the power supply output capacity. Under worst case conditions however, the ripple current may reach $I_{cont} / 2$. Use capacitors with rated voltage $\geq 35 \text{ V}$ and adequate ripple current to avoid overheating or life time reduction.</p> <p>Remark: If there is an excessive amount of reversed energy present (for example during deceleration of loads with a high inertia or during a vertical movement downwards), there might be the need to add an additional capacitor with a much higher capacitance (for example up to 10'000...47'000 μF) and/or to add a brake chopper, for example maxon DSR 50/5 (309687).</p> <p>Example for C1 worst-case dimensioning: $I_{cont} = 1.5 \text{ A} \rightarrow$ Panasonic (EEHZA1H470P) / Kyocera (APA0809470M050R); 47 μF, 50 V, 1550 mA r.m.s.</p>																
Motor Choke (L)	<p>Inductance: \rightarrow "Motor Cables and Motor Chokes" on page 4-66 Rated current: $I_{rms} \geq I_{cont}; I_{sat} \geq I_{peak}$ Construction: shielded</p> <p>33 μH:</p> <table border="0"> <tr> <td>• Eaton (SDCHA1V8040-330-R)</td> <td>$I_{rms} 2.3 \text{ A}, I_{sat} 2.6 \text{ A}, 8 \times 8 \times 3.7 \text{ mm}$</td> </tr> <tr> <td>• Bourns (SRN8040TA-330M)</td> <td>$I_{rms} 2.3 \text{ A}, I_{sat} 2.6 \text{ A}, 8 \times 8 \times 3.7 \text{ mm}$</td> </tr> </table> <p>2.2 μH:</p> <table border="0"> <tr> <td>• Bourns (SRP0412F-2R2M)</td> <td>$I_{rms} 4.2 \text{ A}, I_{sat} 5.5 \text{ A}, 4.3 \times 4.1 \times 1 \text{ mm}$</td> </tr> <tr> <td>• Eaton (MPIA4020V3-2R2-R)</td> <td>$I_{rms} 3.8 \text{ A}, I_{sat} 5.5 \text{ A}, 4.4 \times 4.2 \times 1.8 \text{ mm}$</td> </tr> </table>	• Eaton (SDCHA1V8040-330-R)	$I_{rms} 2.3 \text{ A}, I_{sat} 2.6 \text{ A}, 8 \times 8 \times 3.7 \text{ mm}$	• Bourns (SRN8040TA-330M)	$I_{rms} 2.3 \text{ A}, I_{sat} 2.6 \text{ A}, 8 \times 8 \times 3.7 \text{ mm}$	• Bourns (SRP0412F-2R2M)	$I_{rms} 4.2 \text{ A}, I_{sat} 5.5 \text{ A}, 4.3 \times 4.1 \times 1 \text{ mm}$	• Eaton (MPIA4020V3-2R2-R)	$I_{rms} 3.8 \text{ A}, I_{sat} 5.5 \text{ A}, 4.4 \times 4.2 \times 1.8 \text{ mm}$								
• Eaton (SDCHA1V8040-330-R)	$I_{rms} 2.3 \text{ A}, I_{sat} 2.6 \text{ A}, 8 \times 8 \times 3.7 \text{ mm}$																
• Bourns (SRN8040TA-330M)	$I_{rms} 2.3 \text{ A}, I_{sat} 2.6 \text{ A}, 8 \times 8 \times 3.7 \text{ mm}$																
• Bourns (SRP0412F-2R2M)	$I_{rms} 4.2 \text{ A}, I_{sat} 5.5 \text{ A}, 4.3 \times 4.1 \times 1 \text{ mm}$																
• Eaton (MPIA4020V3-2R2-R)	$I_{rms} 3.8 \text{ A}, I_{sat} 5.5 \text{ A}, 4.4 \times 4.2 \times 1.8 \text{ mm}$																
Motor Filter	<p>Example 1</p> <table border="0"> <tr> <td>• Motor Choke L</td> <td>33 μH</td> </tr> <tr> <td>• Filter Capacitor Cf</td> <td>220 pF, 100 V</td> </tr> <tr> <td>• Snubber Capacitor Cs</td> <td>470 pF, 100 V</td> </tr> <tr> <td>• Snubber Resistor Rs</td> <td>390 Ω, 0.1 W</td> </tr> </table> <p>Example 2</p> <table border="0"> <tr> <td>• Motor Choke L</td> <td>2.2 μH</td> </tr> <tr> <td>• Filter Capacitor Cf</td> <td>220 pF, 100 V</td> </tr> <tr> <td>• Snubber Capacitor Cs</td> <td>470 pF, 100 V</td> </tr> <tr> <td>• Snubber Resistor Rs</td> <td>100 Ω, 0.1 W</td> </tr> </table>	• Motor Choke L	33 μH	• Filter Capacitor Cf	220 pF, 100 V	• Snubber Capacitor Cs	470 pF, 100 V	• Snubber Resistor Rs	390 Ω , 0.1 W	• Motor Choke L	2.2 μH	• Filter Capacitor Cf	220 pF, 100 V	• Snubber Capacitor Cs	470 pF, 100 V	• Snubber Resistor Rs	100 Ω , 0.1 W
• Motor Choke L	33 μH																
• Filter Capacitor Cf	220 pF, 100 V																
• Snubber Capacitor Cs	470 pF, 100 V																
• Snubber Resistor Rs	390 Ω , 0.1 W																
• Motor Choke L	2.2 μH																
• Filter Capacitor Cf	220 pF, 100 V																
• Snubber Capacitor Cs	470 pF, 100 V																
• Snubber Resistor Rs	100 Ω , 0.1 W																
RS232 (IC1) (C3...C7)	<table border="0"> <tr> <td>RS232 transceiver (IC1)</td> <td> <ul style="list-style-type: none"> • Texas Instruments (MAX202IPW) • ST Microelectronics (ST202EBTR) </td> </tr> <tr> <td>Capacitors (C3...C7)</td> <td>100 nF, X7R, 16 V</td> </tr> </table>	RS232 transceiver (IC1)	<ul style="list-style-type: none"> • Texas Instruments (MAX202IPW) • ST Microelectronics (ST202EBTR) 	Capacitors (C3...C7)	100 nF, X7R, 16 V												
RS232 transceiver (IC1)	<ul style="list-style-type: none"> • Texas Instruments (MAX202IPW) • ST Microelectronics (ST202EBTR) 																
Capacitors (C3...C7)	100 nF, X7R, 16 V																

Continued on next page.

Recommended components		
RS422 (IC2) (C8...C10)	RS422 transceiver (IC2)	Renesas/Intersil (ISL8490EIBZ-T)
	Capacitors (C8...C9)	220 pF, COG/NPO, 50 V
	Capacitors (C10)	100 nF, X6S/X7R, 16 V
Resistors (R0...R4)	Resistors (R0; R3)	20 k Ω , 0.063W
	Resistors (R1; R2)	150 Ω , 0.063W
	Resistors (R4)	22 k Ω , 0.063 W
TVS Diode (D3) (C11)	TVS diode (D3) • Nexperia PESD5V0L4UG • ST ESDALC6V1W5	$U_{BR} = 6.46...7.14 \text{ V @ } 1 \text{ mA}$, $V_C = 13 \text{ V @ } 2.5 \text{ A}$ $U_{BR} = 6.46...7.2 \text{ V @ } 1 \text{ mA}$
	Capacitor (C11)	100 nF, X7R, 16 V

Table 4-87 Motherboard Design Guide – Recommended components

4.2 Design Guidelines

The following instructions are intended to serve as an aid when designing an application-specific motherboard and ensures the correct and reliable integration of the Micro.

While designing a motherboard, consider the following characteristics of the Micro:

- Pin assignment (→page 3-18)
- Technical data (→page 2-11) and dimensional drawing (→page 2-15)

4.2.1 Ground

All ground connections (GND) should be internally connected to the Micro (equal potential). It is customary to equip the motherboard with a ground plane. All ground connections should be connected to the voltage supply ground via wide conductive tracks.

Pin	Signal	Description
A25	GND	Ground
A27...A32	GND	Ground
A57...A58	GND	Ground
A63...A64	GND	Ground
A75...A76	GND	Ground
Mounting holes	GND	Ground connections for spacers

Table 4-88 Motherboard Design Guide – Grounding

If an earth potential is in place or required, the ground plane should be connected to the earth potential via one or more capacitors. The use of ceramic capacitors with 100 nF and 100 V is recommended.

4.2.2 Layout

Guidelines for the layout of the motherboard:

- Connector pins [A19...A24] for +V_{CC} (nominal power supply voltage) should be connected to the fuse via wide conductive tracks.
- Connector pins [A25], [A27...A32], [A57], [A58], [A63], [A64], [A75], and [A76] for GND (ground) should be connected with the operating voltage ground via wide conductive tracks.
- The width of the conductive tracks and the copper coating thickness of the conductors for supply voltage and motor depend on the current required in your application. A minimum track width of 75 mil and a minimum copper coating thickness of 35 µm are recommended.

4.3 Terminal/Socket Placement & SMT Footprint

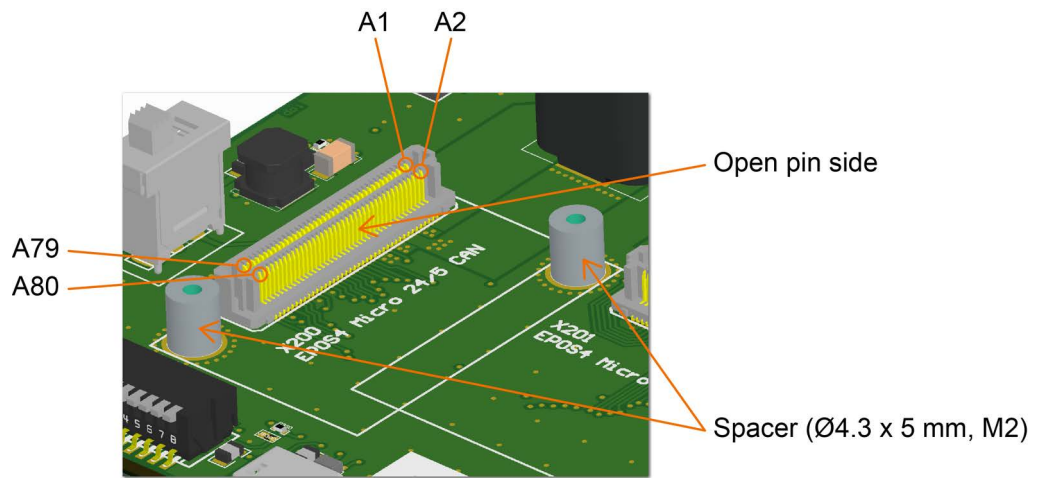

Figure 4-46 EPOS4 Micro 24/1.5 CAN – Terminal/socket placement (example)



Mirroring of terminal rows

The socket is of hermaphroditic design. When mating the Module's socket onto the motherboard's socket, you must consider to mirror the pinning of the motherboard's socket (→Figure 4-47, left, blue shaded).

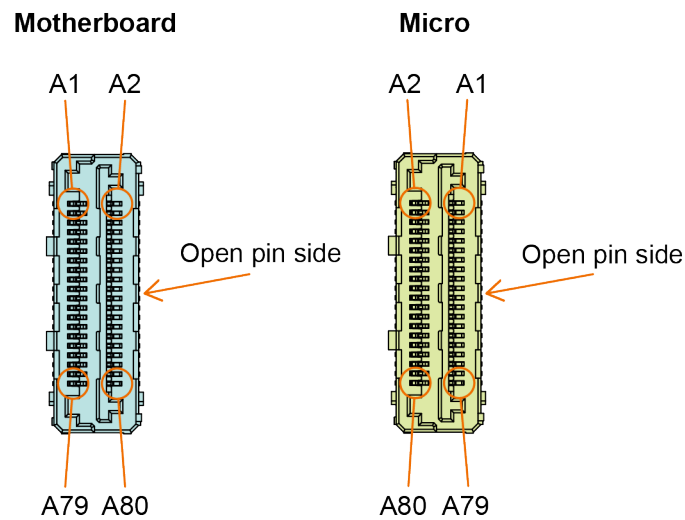

Figure 4-47 EPOS4 Micro 24/1.5 CAN – Terminal/socket placement (mating)

5 WIRING

In this section you will find the wiring information for the setup you are using. You can either use the consolidated wiring diagram (→ Figure 5-50) featuring the full scope of interconnectivity and pin assignment. Or you may wish to use the connection overviews for either DC motor or EC (BLDC) motor that will assist you in determining the wiring for your particular motor type and the appropriate feedback signals

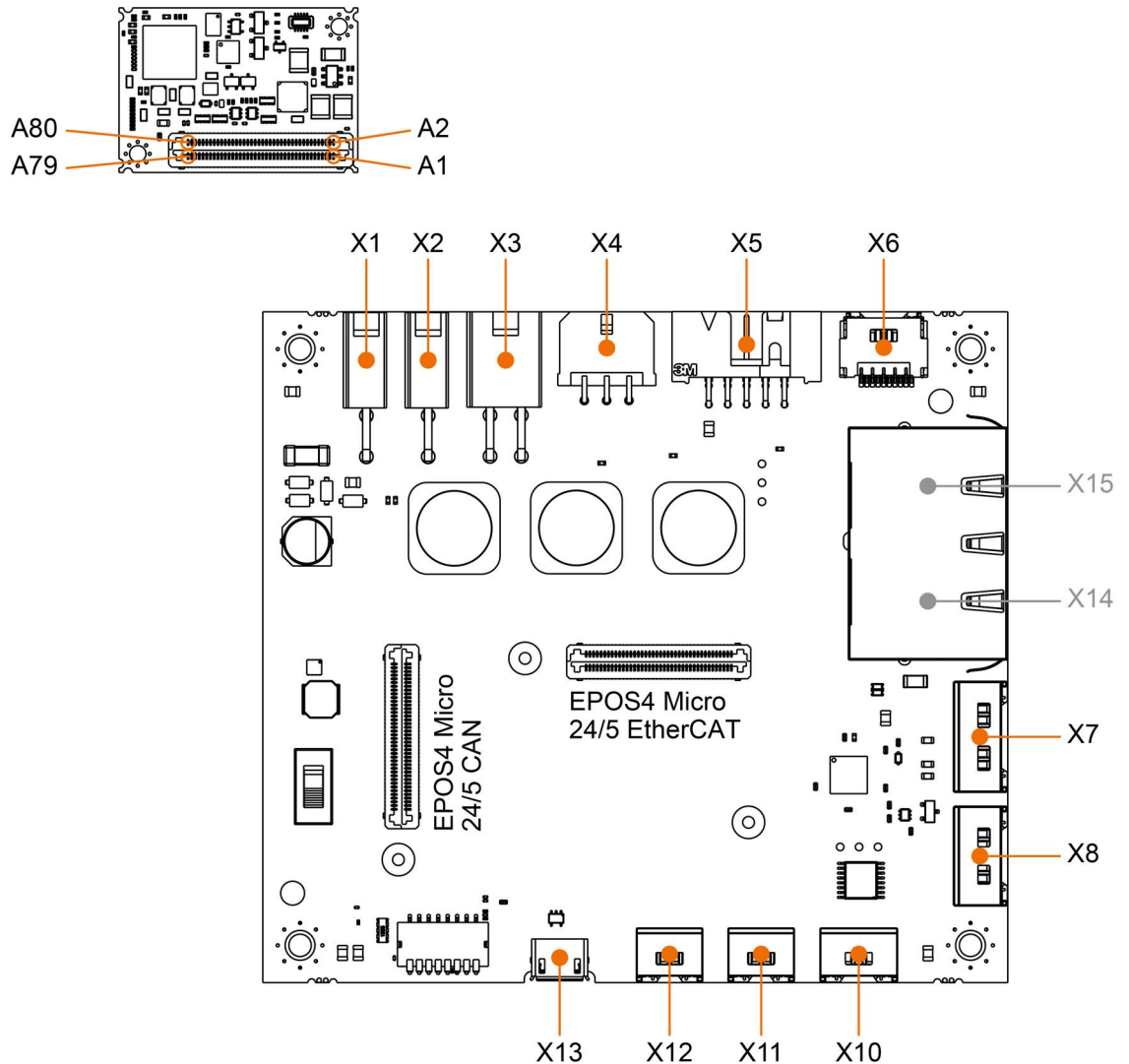



Figure 5-49 Interfaces – Designations and location



Signs and abbreviations used

The subsequent diagrams feature these signs and abbreviations:

- «EC Motor» stands for brushless EC motor (BLDC).
-  Ground safety earth connection (optional).

5.1 Possible Combinations to connect a Motor

The following tables show feasible ways on how to connect the motor with its respective feedback signals or possible combinations thereof. To find the wiring that best suits your setup, proceed as follows:

- 1) Decide on the type of motor you are using; either DC or EC (BLDC) motor.
- 2) Connect the power supply and the logic supply by following the link to the stated figure.
- 3) Check-out the listing for the combination that best suits your setup. Pick the wiring method # and go to the respective table; for DC motor → Table 5-89, for EC (BLDC) motor → Table 5-90.
- 4) Pick the row with the corresponding wiring method # and follow the link (or links) to the stated figure(s) to find the relevant wiring information.

5.1.1 DC Motor

Power supply & optional logic supply Figure 5-51

Motor & feedback signals

Without sensor Method # DC1
 Digital incremental encoder Method # DC2
 SSI absolute encoder Method # DC5
 Digital incremental encoder & SSI absolute encoder Method # DC8

Method #	Digital Incremental Encoder 1 (Sensor 1) X5	SSI Absolute Encoder (Sensor 2) X6	→ Figure(s)
DC1			5-52
DC2	✓		5-52 5-55
DC5		✓	5-52 5-56
DC8	✓	✓	5-52 5-55 / 5-56

Table 5-89 Possible combinations of feedback signals for DC motor

5.1.2 EC (BLDC) Motor

Power supply & optional logic supply Figure 5-51

Motor & feedback signals

Hall sensors Method # EC1

Hall sensors & Digital incremental encoder Method # EC2

Hall sensors & SSI absolute encoder Method # EC5

Hall sensors & Digital encoder & SSI absolute encoder Method # EC8

Digital incremental encoder & SSI absolute encoder Method # EC9

SSI absolute encoder Method # EC10

Method #	Hall sensors (Sensor 3) X4	Digital Incremental Encoder 1 (Sensor 1) X5	SSI Absolute Encoder (Sensor 2) X6	→ Figure(s)
EC1	✓			5-53 5-54
EC2	✓	✓		5-53 5-54 / 5-55
EC5	✓		✓	5-53 5-54 / 5-56
EC8	✓	✓	✓	5-53 5-54 / 5-55 / 5-56
EC9		✓	✓	5-53 5-55 / 5-56
EC10			✓	5-53 5-56

Table 5-90 Possible combinations of feedback signals for EC (BLDC) motor

5.2 Main Wiring Diagram

5.2.1 Micro & EvaBo

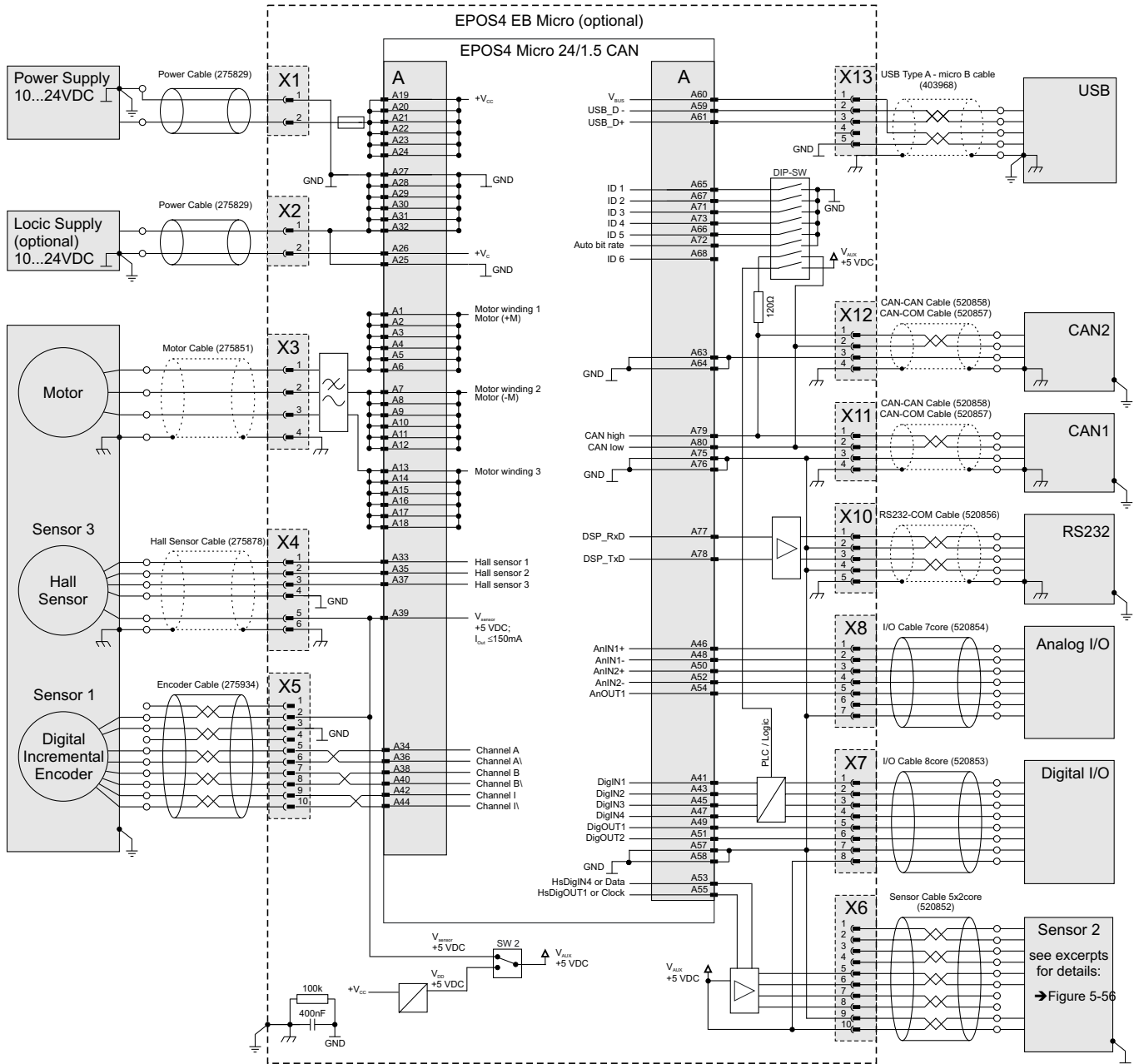

Figure 5-50 Main wiring diagram – Micro & EvaBo

5.3 Excerpts

5.3.1 Power & Logic Supply

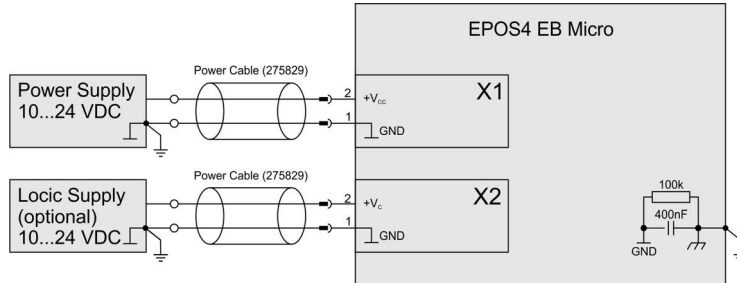

Figure 5-51 Power & logic supply

5.3.2 DC Motor

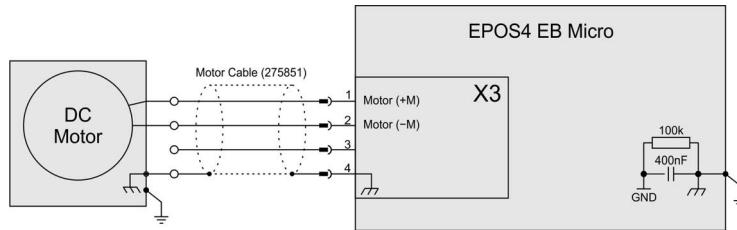

Figure 5-52 DC motor

5.3.3 EC (BLDC) Motor

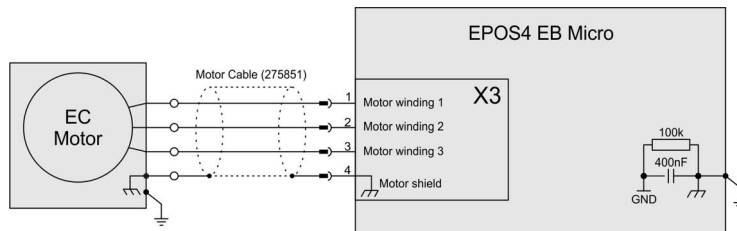

Figure 5-53 EC (BLDC) motor

5.3.4 Hall Sensors (Sensor 3)

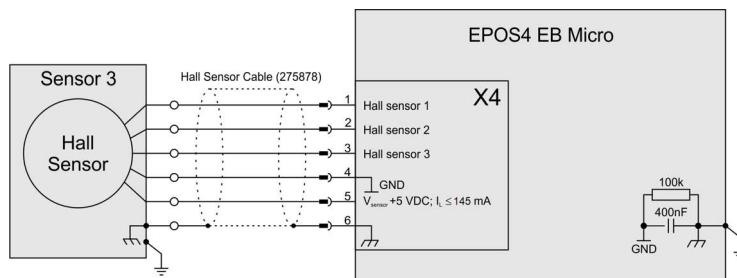

Figure 5-54 Hall sensors (Sensor 3)

5.3.5 Digital Incremental Encoder 1 (Sensor 1)

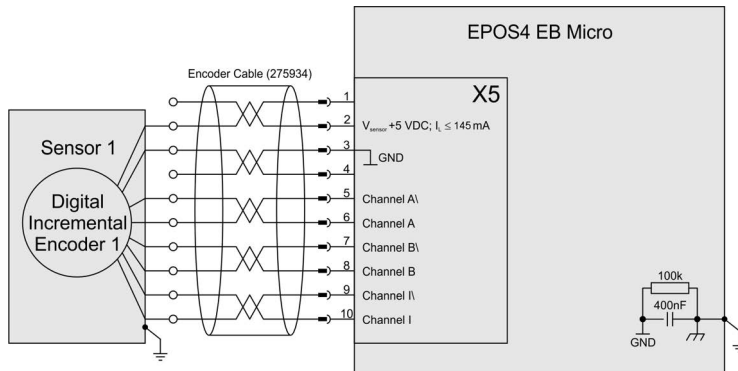

Figure 5-55 Digital incremental encoder 1 (Sensor 1)

5.3.6 SSI Encoder (Sensor 2)

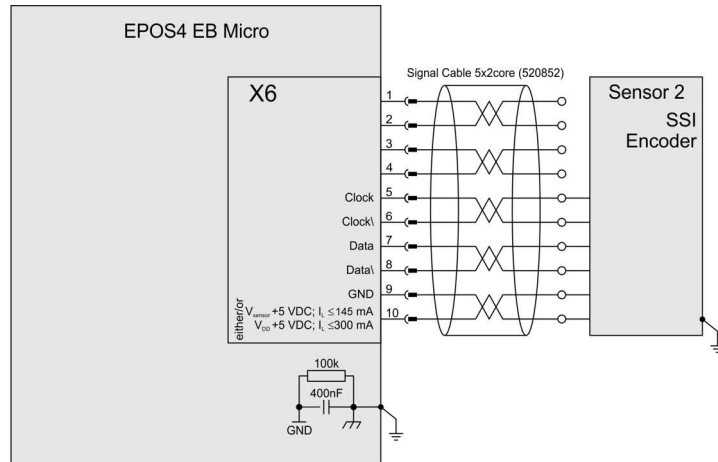

Figure 5-56 SSI encoder (Sensor 2)

LIST OF FIGURES

Figure 1-1	Documentation structure	5
Figure 2-2	Derating of output current	13
Figure 2-3	Power dissipation and efficiency – EPOS4 Micro 24/1.5 CAN	14
Figure 2-4	EPOS4 Micro 24/1.5 CAN – Dimensional drawing [mm].	15
Figure 2-5	EPOS4 EB Micro – Dimensional drawing [mm]	15
Figure 3-6	Pin assignment	18
Figure 3-7	EPOS4 EB Micro (without/with EPOS4 Micro 24/1.5 CAN)	20
Figure 3-8	Connector Boards – Connectors	22
Figure 3-9	Power supply connector X1.	23
Figure 3-10	Logic supply connector X2	24
Figure 3-11	Motor connectors X3	25
Figure 3-12	Hall sensor connector X4	26
Figure 3-13	Encoder connector X5.	27
Figure 3-14	Sensor connector X6.	28
Figure 3-15	Digital I/O connector X7	29
Figure 3-16	Analog I/O connector X8	30
Figure 3-17	RS232 connector X10	31
Figure 3-18	CAN 1 connector X11/CAN 2 connector X12	32
Figure 3-19	USB connector X13.	33
Figure 3-20	EvaBo switches – Location	34
Figure 3-21	Hall sensor 1 input circuit (analogously valid for Hall sensors 2 & 3)	40
Figure 3-22	Encoder input circuit Ch A “differential” (analogously valid for Ch B & Ch I).	42
Figure 3-23	Encoder input circuit Ch A “single-ended” (analogously valid for Ch B & Ch I).	43
Figure 3-24	SSI absolute encoder data input	45
Figure 3-25	SSI absolute encoder clock output	45
Figure 3-26	HsDigIN4 circuit “differential”.	46
Figure 3-27	HsDigIN4 circuit “single-ended”.	47
Figure 3-28	HsDigOUT1 output circuit	48
Figure 3-29	DigIN1 circuit (analogously valid for DigIN2...4) – Micro	49
Figure 3-30	DigIN1 circuit (analogously valid for DigIN2...4) – EvaBo / Logic level setting.	50
Figure 3-31	DigIN1 circuit (analogously valid for DigIN2...4) – EvaBo / PLC level setting.	51
Figure 3-32	DigOUT1 circuit (analogously valid for DigOUT2).	52
Figure 3-33	DigOUT1 “sinks” (analogously valid for DigOUT2 and EvaBo).	53
Figure 3-34	DigOUT1 “source” (analogously valid for DigOUT2 and EvaBo)	53
Figure 3-35	AnIN1 circuit (analogously valid for AnIN2).	54
Figure 3-36	AnOUT1 circuit	55
Figure 3-37	SCI circuit	56
Figure 3-38	LEDs – Location	61
Figure 4-39	Wiring of power supply	64
Figure 4-40	Wiring of logic supply	65
Figure 4-41	Wiring of motor winding 1 (analogously valid also for motor windings 2 & 3).	67

Figure 4-42	Wiring of RS232 transceiver	68
Figure 4-43	Wiring of RS422 transceiver	68
Figure 4-44	USB protection circuitry	69
Figure 4-45	High-speed digital input/output and sensor protection circuitry	69
Figure 4-46	EPOS4 Micro 24/1.5 CAN – Terminal/socket placement (example)	73
Figure 4-47	EPOS4 Micro 24/1.5 CAN – Terminal/socket placement (mating)	73
Figure 4-48	EPOS4 Micro 24/1.5 CAN – Terminal/socket footprint	74
Figure 5-49	Interfaces – Designations and location	75
Figure 5-50	Main wiring diagram – Micro & EvaBo	78
Figure 5-51	Power & logic supply	79
Figure 5-52	DC motor	79
Figure 5-53	EC (BLDC) motor	79
Figure 5-54	Hall sensors (Sensor 3)	79
Figure 5-55	Digital incremental encoder 1 (Sensor 1)	80
Figure 5-56	SSI encoder (Sensor 2)	80

LIST OF TABLES

Table 1-1	Notation used	6
Table 1-2	Symbols and signs	6
Table 1-3	Brand names and trademark owners	7
Table 1-4	Abbreviations.	8
Table 2-5	Technical data	12
Table 2-6	Limitations	14
Table 2-7	Standards	16
Table 3-8	Pin assignment A1...A80	19
Table 3-9	Prefab maxon cables.	20
Table 3-10	EPOS4 Connector Set – Content	21
Table 3-11	Recommended tools	21
Table 3-12	Power supply connector X1 – Pin assignment	23
Table 3-13	Power Cable	23
Table 3-14	Logic supply connector X2 – Pin assignment	24
Table 3-15	Motor connector X3 – Pin assignment for maxon DC motor.	25
Table 3-16	Motor connector X3– Pin assignment for maxon EC motor	25
Table 3-17	Motor Cable.	25
Table 3-18	Hall sensor connector X4 – Pin assignment	26
Table 3-19	Hall Sensor Cable	26
Table 3-20	Encoder connector X5 – Pin assignment	27
Table 3-21	Encoder connector X5 – Accessories	27
Table 3-22	Encoder Cable	27
Table 3-23	Sensor connector X6 – Pin assignment	28
Table 3-24	Sensor Cable 5x2core.	28
Table 3-25	Digital I/O connector X7 – Pin assignment	29
Table 3-26	Signal Cable 8core	29
Table 3-27	Analog I/O connector X8 – Pin assignment.	30
Table 3-28	Signal Cable 7core	30
Table 3-29	RS232 connector X10 – Pin assignment.	31
Table 3-30	RS232-COM Cable	31
Table 3-31	CAN 1 connector X11/CAN 2 connector X12 – Pin assignment	32
Table 3-32	CAN-COM Cable.	32
Table 3-33	CAN-CAN Cable	32
Table 3-34	USB connector X13 – Pin assignment	33
Table 3-35	USB Type A - micro B Cable.	33
Table 3-36	USB interface specification	33
Table 3-37	EvaBo DIP switch SW1 – Binary code values.	34
Table 3-38	EvaBo DIP switch SW1 – Examples.	35
Table 3-39	EvaBo DIP switch SW1 – CAN automatic bit rate detection	35
Table 3-40	EvaBo DIP switch SW1 – CAN bus termination	35
Table 3-41	EvaBo DIP switch SW1 – Digital input level	36

Table 3-42	Voltage outputs – Source	36
Table 3-43	Voltage outputs – Specifications	36
Table 3-44	Power supply – Pin assignment	37
Table 3-45	Power supply requirements	37
Table 3-46	Logic supply – Pin assignment	38
Table 3-47	Logic supply requirements	38
Table 3-48	DC motor – Pin assignment	39
Table 3-49	EC motor – Pin assignment	39
Table 3-50	Hall sensor – Pin assignment	40
Table 3-51	Hall sensor specification	40
Table 3-52	Encoder – Pin assignment	41
Table 3-53	Differential encoder specification	41
Table 3-54	Single-ended encoder specification	42
Table 3-55	SSI absolute encoder – Pin assignment	44
Table 3-56	SSI absolute encoder specification (Micro)	44
Table 3-57	SSI absolute encoder specification (EvaBo)	44
Table 3-58	High-speed digital I/Os – Pin assignment	46
Table 3-59	Differential high-speed digital input specification	46
Table 3-60	Single-ended high-speed digital input specification (Micro)	47
Table 3-61	Single-ended high-speed digital input specification (EvaBo)	47
Table 3-62	High-speed digital output specification (EvaBo)	47
Table 3-63	High-speed digital output specification (EvaBo)	48
Table 3-64	Digital inputs – Pin assignment – Micro	49
Table 3-65	Digital input specification – Micro	49
Table 3-66	Digital inputs – Pin assignment – EvaBo	50
Table 3-67	Digital input specification – Logic level setting	50
Table 3-68	Digital input specification – PLC level setting	51
Table 3-69	Digital outputs – Pin assignment – Micro	52
Table 3-70	Digital output specification	52
Table 3-71	Digital output – Sinks	53
Table 3-72	Digital output – Source	53
Table 3-73	Analog I/Os – Pin assignment	54
Table 3-74	Analog input specification	54
Table 3-75	Analog output specification	55
Table 3-76	SCI – Pin assignment	56
Table 3-77	SCI specification	56
Table 3-78	RS232 – Pin assignment	57
Table 3-79	RS232 interface specification	57
Table 3-80	CAN bus line / CAN 1 / CAN 2 – Pin assignment	58
Table 3-81	CAN interface specification	58
Table 3-82	ID – Pin assignment	59
Table 3-83	CAN ID specification	59
Table 3-84	ID – Examples	60
Table 3-85	Bit rate detection specification	60

Table 3-86	Device Status LEDs	61
Table 4-87	Motherboard Design Guide – Recommended components	71
Table 4-88	Motherboard Design Guide – Grounding	72
Table 5-89	Possible combinations of feedback signals for DC motor	76
Table 5-90	Possible combinations of feedback signals for EC (BLDC) motor	77

••page intentionally left blank••

INDEX

A

abbreviations used 8
 alerts 6
 analog inputs 54
 analog outputs 55
 applicable EU directive 17
 applicable regulations 9

B

bit rate detection 35, 60
 bit rate, default 58
 BLDC motor, connection 18, 39

C

C1 (capacitor) 64
 cables (prefab)
 CAN-CAN Cable 32
 CAN-COM Cable 32
 Encoder Cable 27
 Hall Sensor Cable 26
 Motor Cable 25
 Power Cable 23
 RS232-COM Cable 31
 Sensor Cable 5x2core 28
 Signal Cable 7core 30
 Signal Cable 8core 29
 USB Type A - micro B Cable 33

CAN bus termination 35, 58

CAN ID (see "ID")

CAN interface 58

choke, motor 66

connectors

X1 23
 X10 31
 X11 32
 X12 32
 X13 33
 X2 24
 X3 25
 X4 26
 X5 27
 X6 28
 X7 29
 X8 30

country-specific regulations 9

D

D1 (DVS diode) 64
 D2 (DVS diode) 65
 DC motor, connection 18, 39
 device condition, display of 61
 digital high-speed inputs (differential) 46
 digital high-speed inputs (single-ended) 47
 digital high-speed output 47, 48

digital inputs 49
 digital outputs 52
 DIP switch SW1 34

E

EC motor, connection 18, 39

encoders

 absolute 44
 differential 41
 serial 44
 single-ended 42

EPOS4 Connector Set 21

ESD 9

ESD protection circuitry for MoBo 69

EU directive, applicable 17

F

footprint 73
 FU1 (input fuse) 64

H

Hall sensor 40

how to

 calculate the required supply voltage 37
 get help in designing the motherboard 63
 interpret icons (and signs) used in this document 6

I

ID (of the device) 34

incorporation into surrounding system 17

informatory signs 6

inputs

 analog 54
 digital 49
 high-speed digital 46

interfaces

 CAN 32, 58
 location and designation 75
 RS232 31, 56
 SCI 56
 USB 33

internal motor chokes 66

L

LEDs, interpretation of 61

logic supply 38

M

mandatory action signs 6

MoBo, ESD protection circuitry 69

motor choke 66

motor types, supported 8

N

naming of components 8

node address (see "ID")

Node-ID (see "ID")

notations used 6

O

operating license 17

outputs

analog 55

digital 52

high-speed digital 47, 48

P

part numbers

275829 23

275851 25

275878 26

275934 27

403968 33

520852 28

520853 29

520854 30

520856 31

520857 32

520858 32

520859 21

638677 8, 20

677324 70

951711 8

performance data 11

pin assignment 18

power supply 37

precautions 9

prerequisites prior installation 17

prohibitive signs 6

protective measures (ESD) 9

purpose

of the device 8

of the document 5

R

regulations, applicable 9

RS232 transceiver 68

RS422 68

RS422 transceiver 68

S

safety alerts 6

safety first! 9

SCI (Serial Communication Interface) 56

Serial Communication Interface (SCI) 56

serial encoder 44

signs used 6

spacer (mount) 63

SSI absolute encoder 44

SSI encoder, wiring 80

standards, fulfilled 16

standoff (mount) 63

status LEDs 61

supply voltage, required 37

switches

SW1 34

SW2 36

symbols used 6

T

technical data 11

termination (CAN bus) 35, 58

U

USB port 33

W

wiring examples

additional inductance on Motherboard 66

DC motor 79

digital incremental encoder 80

DigOUT 53

EC (BLDC) motor 79

Hall sensors 79

power & logic supply 79

SSI encoder 80

••page intentionally left blank••



EtherCAT® is a registered trademark and patented technology, licensed by Beckhoff Automation GmbH, Germany

© 2026 maxon. All rights reserved. Any use, in particular reproduction, editing, translation, and copying, without prior written approval is not permitted (contact: maxon international ltd., Brünigstrasse 220, CH-6072 Sachseln, +41 41 666 15 00, www.maxongroup.com). Infringements will be prosecuted under civil and criminal law. The mentioned trademarks belong to their respective owners and are protected under trademark laws. Subject to change without prior notice.